

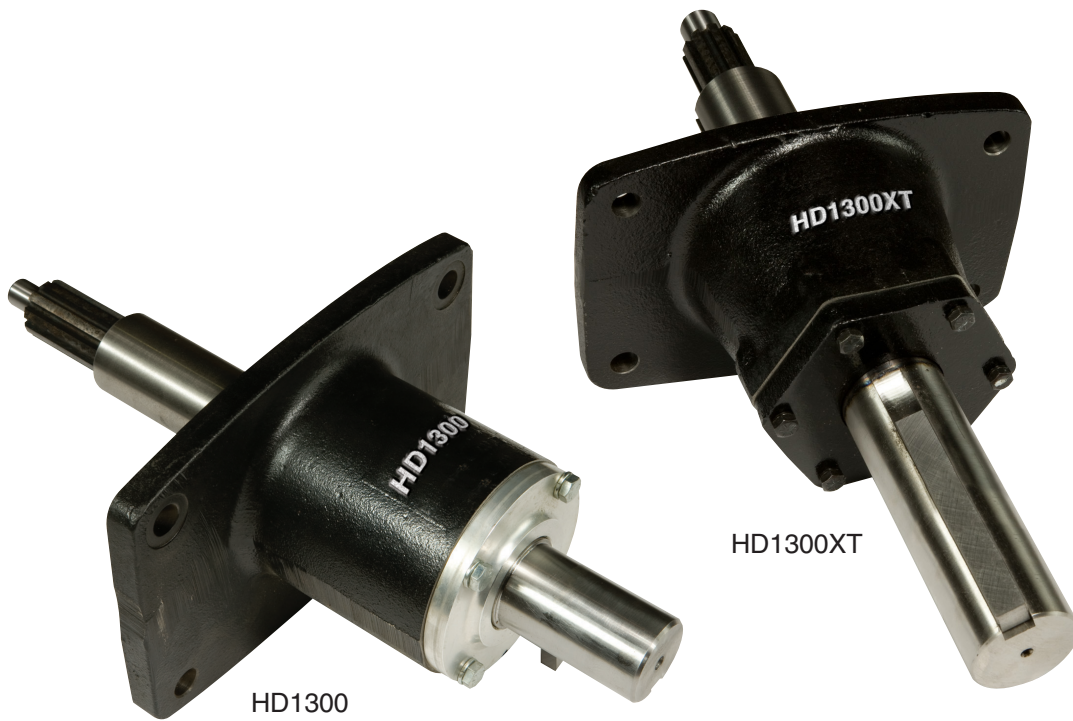

Industrial Spring Loaded PTO



# Owner's Manual

# Table of Contents

General Information	1
Clutch Operation	2
Engaging the Clutch	2
Disengaging the Clutch	3
Clutch Adjustment (HD1300)	3
Clutch Adjustment (HD1300XT)	4
Lubrication	4
Service Parts HD1300 PTO Assy. 1 3/4" & 2.25" Shaft	5
Exploded View HD1300 Lever Assy. and Linkage	6
Service Parts HD1300 Lever Assy. and Linkage	7
Service Parts HD1300 Clutch and Housing	8
Service Parts HD1300XT150 PTO Assy. 2 1/4" Shaft	9
Exploded View HD1300XT150 Lever Assy. and Linkage	10
Service Parts HD1300XT150 Lever Assy. and Linkage	11
Service Parts HD1300XT150 Clutch and Housing Assy.	12
Service Parts HD1300XT175 PTO Assy. 2 1/4" Shaft	13
Exploded View HD1300XT175 Lever Assy. and Linkage	14
Service Parts HD1300XT175 Lever Assy. and Linkage	15
Service Parts HD1300XT175 Clutch and Housing	16
Warranty Statement	17

## General Information

The AUTO Mfg. Inc. clutch and PTO is a heavy-duty assembly capable of providing full engine horsepower from the PTO output shaft. Designed for use on both gasoline and diesel engines, the main components for each engine are the same.

Three models of the clutch and PTO are available:

### HD1300 PTO

The **HD1300** provides a 1¾" output shaft for use on gasoline and diesel engines. This assembly incorporates three heavy-duty ball bearings (one at the front and two at the rear of the housing), 1 3/8" splined shaft, with hardened spline and bearing journals.

The 13" clutch disc with 1 3/8" heat treated splined hub and ceramic metallic pads is designed for medium-duty industrial applications up to 120hp.

The industrial style pressure plate incorporates 12 springs providing a clamping force of 1825 lbs.

### HD1300XT150

The **HD1300XT150** provides a 2¼" output shaft with hardened spline and journals for use on diesel engines up to 150hp. The PTO assembly utilizes a 2 row heavy-duty ball bearing at the rear and a single row ball bearing at the front of the PTO housing.

The 13" clutch disc with 1½" heat treated splined hub and ceramic metallic pads is designed for heavy-duty industrial applications up to 150hp.

The industrial style pressure plate incorporates 12 springs providing a clamping force of 1825 lbs. An optional heavy duty pressure plate with 16 springs and 2425 lbs. of clamp load is also available.

### HD1300XT175

The **HD1300XT175** provides a 2¼" output shaft with hardened spline and journals and is recommended for use on diesel engines from 140hp to 180hp used in heavy duty industrial application. The PTO assembly utilizes a 2 row heavy-duty ball bearing at the rear and a single row ball bearing at the front of the PTO housing.

The 13" clutch disc with 1¾" heat treated splined hub and ceramic metallic pads, and the heavy duty pressure plate providing 2425 lbs. of clamp load allows this PTO assembly to be used in heavy-duty applications up to 175hp.

### PTO Shaft Pilot Bearing

The PTO output shaft in all models is centered into a pilot bearing located in the engine flywheel.

### PTO and Clutch Assemblies

The PTO and clutch assemblies are designed for use on either in-line or belt driven applications. A drive shaft utilizing universal joints must be used with in-line installations to compensate for engine and driven unit misalignment.

### Technical and Application Requests

Questions concerning the installation of the clutch/PTO and/or its application should be directed to Auto Mfg. Inc. Engineering Technical Group at ph. 800 551-2938.

# Clutch Operation

## **WARNING**

ROTATING SHAFTS, PULLEYS,  
AND MOVING BELTS CAN CAUSE  
SEVERE INJURY OR CAN BE FATAL.

THE ENGINE AND DRIVEN UNIT  
MUST BE STOPPED BEFORE ANY  
ADJUSTMENTS OR WORK IS  
ATTEMPTED TO THE ENGINE, DRIVEN  
UNIT, OR THE PTO CLUTCH ITSELF.

The **AUTO clutch** is disengaged with the handle in the 'down' or 'horizontal' position (Fig. 1). It is recommended that the engine be started with the clutch disengaged.

If the engine is being started for the first time during the workday, allow the engine to **WARM UP** for a few minutes before engaging the clutch.

## **Engaging the Clutch**

For mechanical throttle actuated engines, increase the engine rpm to approximately 1000 to 1200 rpm. Engage the clutch by moving the clutch handle to the 'up' or 'vertical' position (Fig. 2) slowly enough to prevent stalling the engine.

For electronic throttle controlled engines, engage the clutch with the throttle control in the slow idle position. Use caution when engaging the clutch, not to allow excessive slippage of the disc prior to full engagement.

## **CAUTION:**

Running the engine with the PTO dis-engaged for extended periods of time can cause failure of the throw-out bearing.

## **CAUTION:**

Excessive slippage during engagement will cause premature failure of the clutch disc. This type of failure is not covered under the clutch warranty.

When the driven equipment is running at the same rpm as the engine allow the clutch to engage fully.

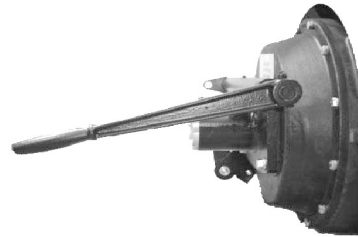

Fig. 1

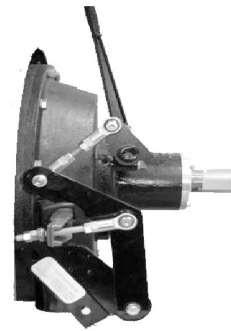

Fig. 2

With the clutch handle in the vertical position and the clutch fully engaged, you can now move the engine throttle to the preferred engine operating position. The PTO output shaft is now rotating at engine rpm.

## **CAUTION:**

Engaging and disengaging the clutch at maximum engine RPM can cause the disc, pressure plate and throw-out bearing to overheat and can result in premature failure of these components. This type of failure is not covered under the clutch warranty.

## Disengaging the Clutch

Properly disengaging the clutch and PTO is as important as the engagement.

1. **DO NOT** disengage the clutch and PTO with the engine running at max rpm.
2. Reduce the engine throttle control slowly allowing the driven rotating components to slow down with the engine. When the engine speed nears 1000 rpm, move the handle of the clutch to the disengaged position.
3. **DO NOT** use the clutch as a 'brake' for the machine rotating components. This type of operation can and will cause fatigue and failure of all clutch components including the engine flywheel

### **CAUTION:**

**DO NOT** use the clutch as a brake for stopping rotating components. This can cause fatigue and failure of all clutch components including the engine flywheel.

## Clutch Adjustment

### **WARNING**

ROTATING SHAFTS, PULLEYS,  
AND MOVING BELTS CAN CAUSE  
SEVERE INJURY OR CAN BE FATAL.

THE ENGINE AND DRIVEN UNIT  
MUST BE STOPPED BEFORE ANY  
ADJUSTMENTS OR WORK IS  
ATTEMPTED TO THE ENGINE, DRIVEN  
UNIT, OR THE PTO CLUTCH ITSELF.

A properly adjusted clutch will provide many hours of service life. Therefore it is important that the adjustment of the clutch linkage be checked after the first 15 hours of operation and every 250 hours thereafter.

An improperly adjusted clutch can result in premature wear to the clutch disc, pressure plate, throw-out bearing, and engine flywheel.

### **HD1300**

1. With the clutch handle in the engaged position, adjust the nut against the 'rocker ball' until a 1/8" gap is obtained between the nut and the 'rocker ball'.
2. Use the 1/8" gauge tool (41500103) to slip between the nut and the rocker ball with a slight amount of pressure.
3. Tighten the lock nut to the adjusting nut.
4. Place the handle in the disengaged position (horizontal). Check to make sure that the PTO output shaft turns freely.

### **HD1300**

DIESEL ENGINES

SK10732C

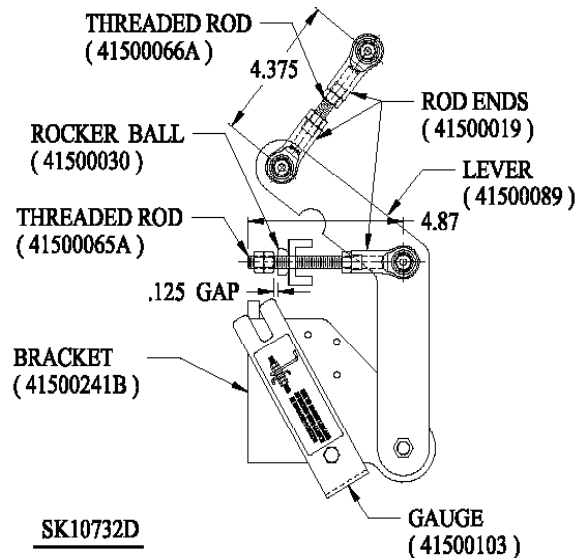

SK10732D

REVISED 03/18/08 WB

## HD1300XT150 & XT175

1. With the clutch handle in the engaged position, adjust the nut against the 'rocker ball' until a 1/8" gap is obtained between the nut and the 'rocker ball'.
2. Use the 1/8" gauge tool (41500103) to slip between the nut and the rocker ball with a slight amount of pressure.
3. Tighten the lock nut to the adjusting nut.
4. Place the handle in the disengaged position (horizontal). Check to make sure that the PTO output shaft turns freely.

## HD1300XT150 & XT175

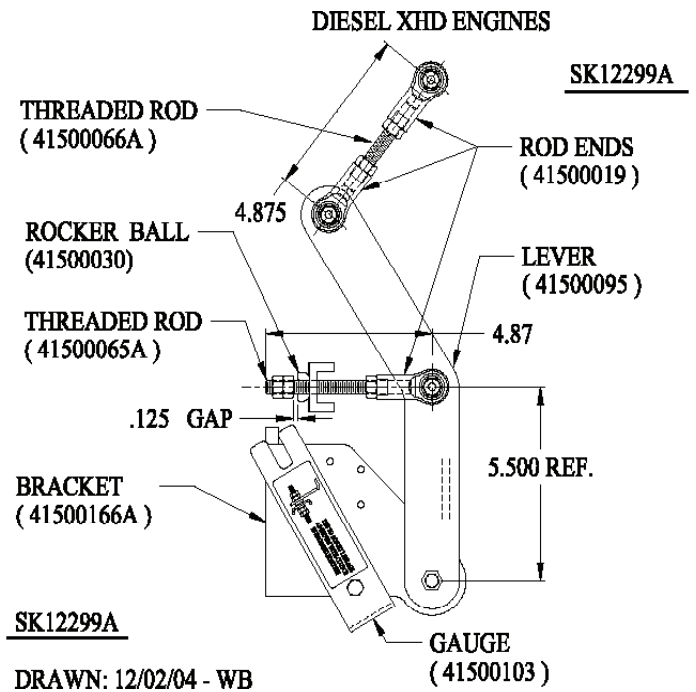

## Lubrication

The PTO assembly on both the HD1300 and HD1300XT150 & XT175 are equipped with Sealed for life bearings. No greasing of the PTO assembly is required.

The clutch lever crossover shaft should be lubricated with a high temperature lithium base #2 lubricant at 250-hour intervals.

The bore of the throw-out bearing must be lubricated with a molybdenum based grease if disassembled for service reasons.

# HD1300

## 1.375" Spline

### 1.75" Output Shaft & 2 .25" Output Shaft

### PTO Assembly

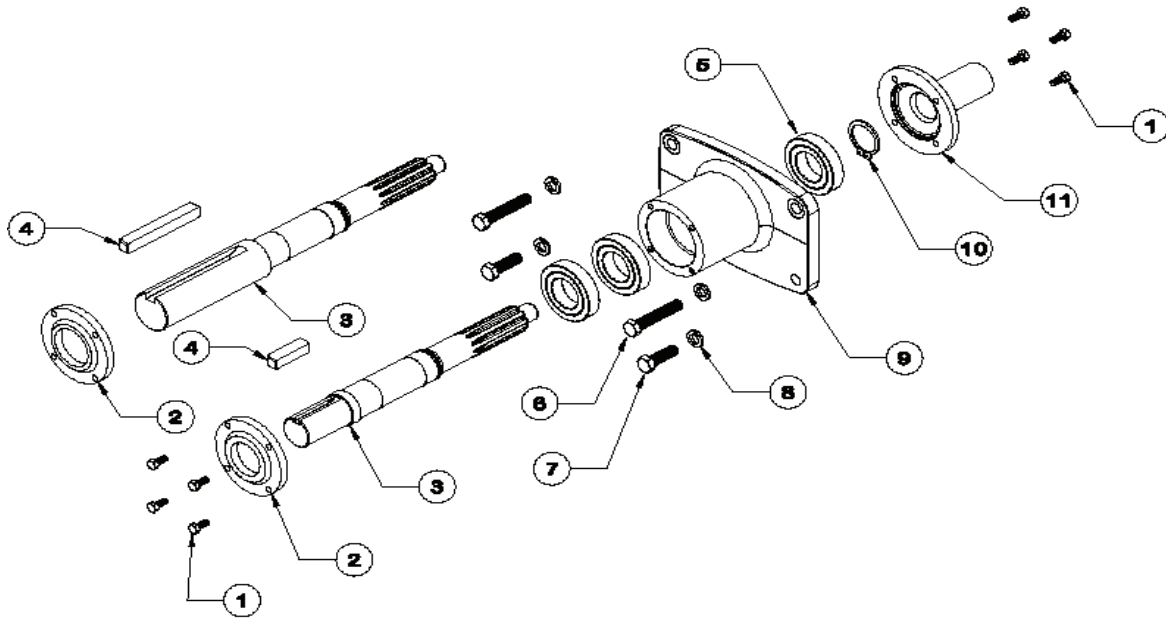

REF. NO.	PART NUMBER	QTY.	DESCRIPTION
1	45000030	8	Bolt, 5/16-18x1", Grade 5
2	41500057	1	Cover. Bearing Retainer, 1 3/4" Shaft
	41500123	1	Cover, Bearing Retainer, 2 1/4" Shaft
3	41500195	1	Shaft, PTO. 1 3/4" Shaft
	41500197	1	Shaft, PTO, 2 1/4" Shaft
4	41500190	1	Key, 1 3/4" Shaft, 3/8" sq. x 2 3/8" Long
	41500126	1	Key, 2 1/4" Shaft, 5/8" sq. x 5" Long
5	41500125	3	Bearing, PTO
6	45000105	2	Bolt, 9/16-12x3" Grade 5
7	45000177	2	Bolt, 9/16-12x1 3/4" Grade 5
8	45000103	4	Washer, Lock 9/16"
9	41500188	1	Housing, PTO
10	41500154	1	Ring, Snap 1 11/16"
11	41500198	1	Housing, Support Throw-out Bearing
	41500194	1	Assembly, 1 3/4" PTO Shaft & Housing
	41500196	1	Assembly, 2 1/4" PTO Shaft & Housing (Includes 1,2,3,4,5,8,10 & 11)

# HD1300

## Lever Assembly and Linkage

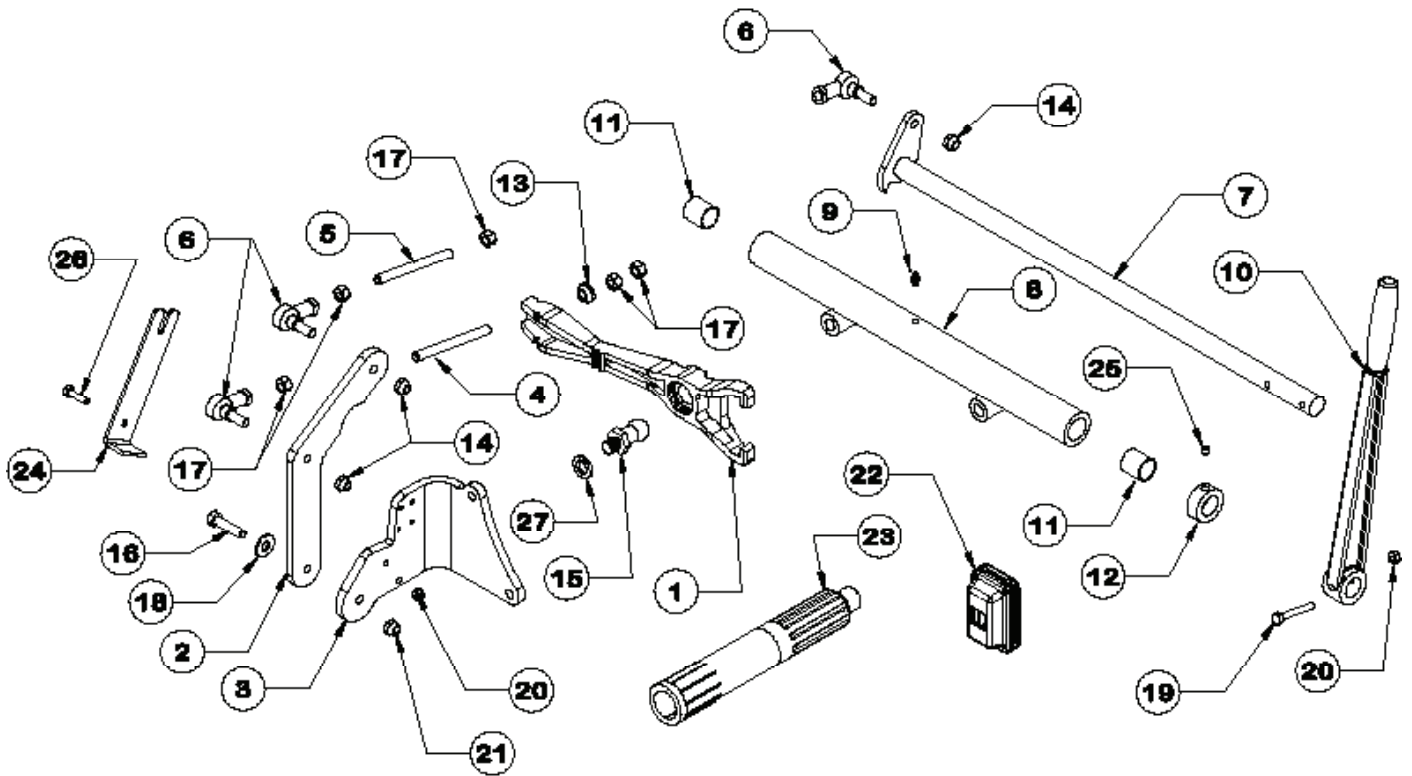

For Parts Breakdown See Next Page

# HD1300

## Lever Assembly and Linkage (con't)

REF. NO.	PART NUMBER	QTY.	DESCRIPTION
1	41500063	1	Fork
Not Shown	41500174	1	Retainer, Clutch Fork
2	41500089	1	Linkage, Lever (Diesel Engine)
3	41500241	1	Bracket, Linkage (Diesel Engine)
4	41500067	1	Rod, Linkage (Diesel Engine)
5	41500066	1	Rod, Linkage (Diesel Engine)
6	41500019	3	Rod End
7	41500101	1	Shaft, Lever
8	41500111	1	Housing, Shaft (Diesel Engine)
9	41500043	1	Zerk, Grease
10	41500044	1	Handle
11	41500045	2	Bushing, Shaft
12	41500046	1	Collar
13	41500030	1	Ball, Rocker
14	45000004	3	Nut, Ny-lock 3/8-24
15	41500001	1	Ball, Pivot (Diesel Engine)
16	45000177	1	Bolt, 3/8-16x1" Grade 5
17	45000225	5	Nut, 3/8-24 Grade 5
18	45000048	1	Flat Washer, 3/8"
19	45000012	1	Bolt, 1/4-28x2" Grade 5
20	45000015	1	Lock Nut, 1/4-28
21	45000051	1	Lock Nut, 3/8-16
22	41500175	1	Boot
23	41500040	1	Tool, Spline Alignment
24	41500103	1	Tool, Adjustment
25	45000028	1	Setscrew - 5/16-18
26	45000014	1	Bolt, 1/4-28x1" Long

# HD1300

## Diesel Engine Clutch and Housing

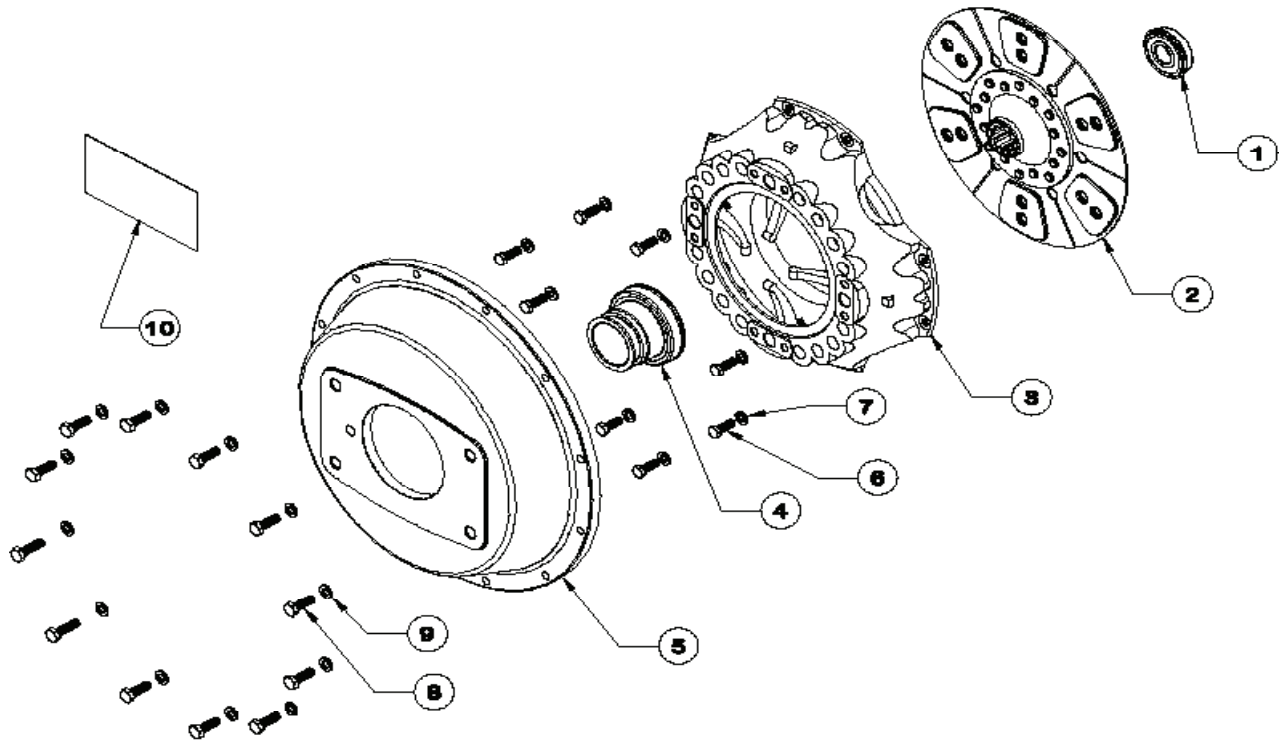

REF. NO.	PART NUMBER	QTY.	DESCRIPTION
1	41500218	1	Pilot Bearing (Perkins, Cummins)
	41500217	1	Pilot Bearing (John Deere)
2	41500234	1	Disc, Clutch (Replaces 48900003)
3	41500060	1	Plate, Clutch Pressure (12 Springs)
4	41500003	1	Bearing, Throw Out
5	41500172	1	Housing, Adapter
6	45000224	8	Bolt, 3/8"-24x1" Grade 5 (Perkins, CAT)
	45000054	8	Bolt, 3/8"-16x1" Grade 5 (John Deere, Cummins)
7	45000063	8	Lock Washer, 3/8"
8	45000043	10	Bolt, M10-1.5x30mm
	45000226	2	Bolt, M10-1.5x35mm (Perkins, CAT, John Deere)
9	45000046	12	Lock Washer, M10
10	41500009	1	Decal, Diesel Clutch

# HD1300XT150

## 1.50" Spline

## 2.25" Output Shaft

## PTO Assembly

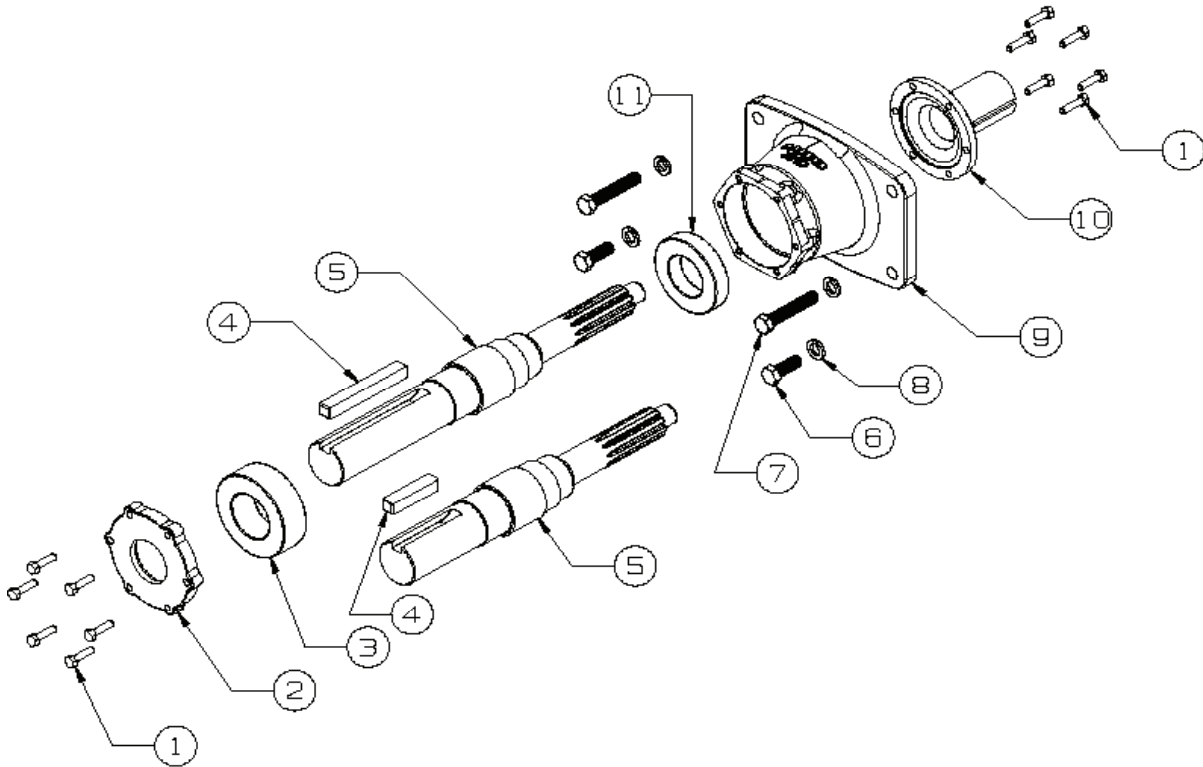

REF. NO.	PART NUMBER	QTY.	DESCRIPTION
1	45000212	12	Bolt, 5/16-18x1.25", Grade 5
2	41500205	1	Cover, Rear
3	41500206	1	Bearing, Rear
4	41500126	1	Key, .625 sq. x 5" Long
		1	Key, .625 sq, x 2.25" Long
5	41500203	1	Shaft, Long (6.56" Tail Shaft)
	41500224	1	Shaft, Short (4.04" Tail Shaft)
6	45000105	2	Bolt, 9/16-12x1 3/4", Grade 5
7	45000177	2	Bolt, 9/16-12x3", Grade 5
8	45000103	4	Lock Washer, 9/16"
9	41500204	1	Housing, PTO
10	41500242	1	Housing, Bearing Retainer
11	41500207	1	Bearing, Front
	41500252	1	Assembly, PTO Shaft & Housing (Long)
	41500253	1	Assembly, PTO Shaft & Housing (Short)

# HD1300XT150

## Lever Assembly and Linkage

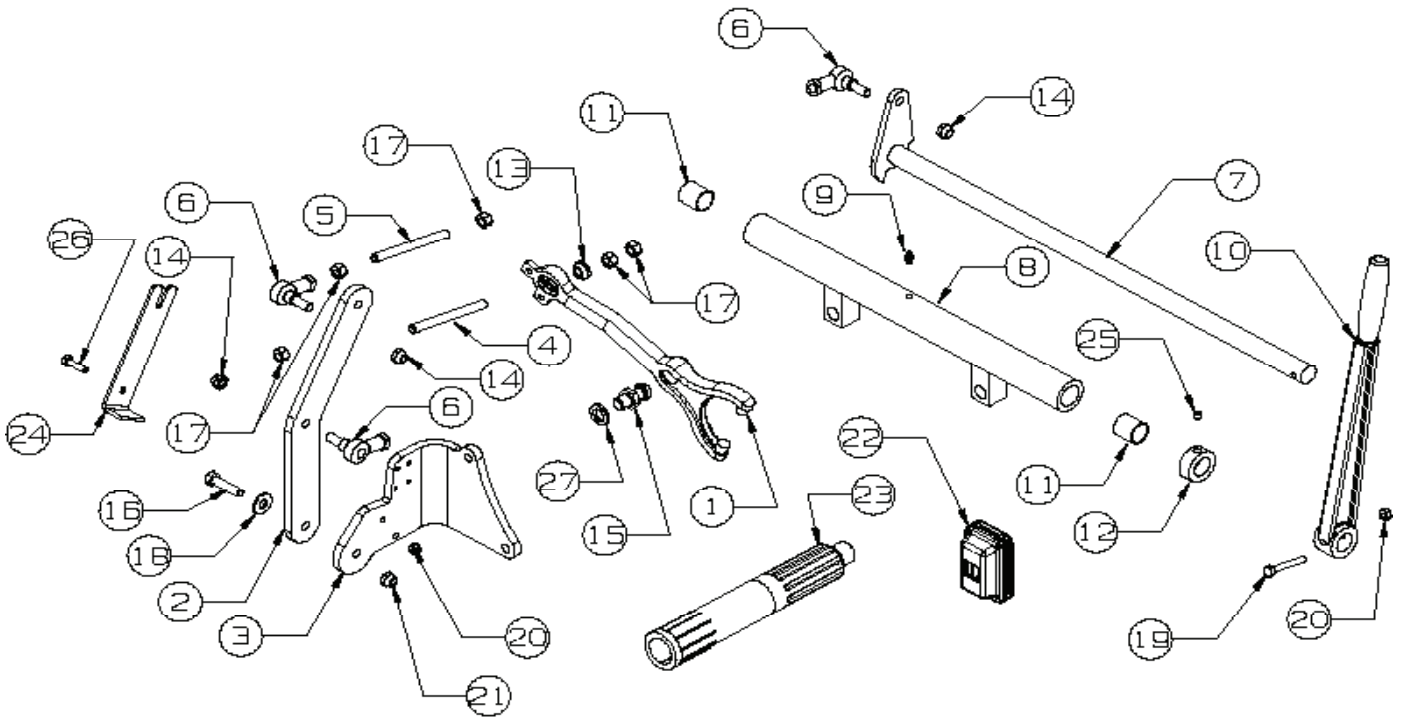

For Parts Breakdown See Next Page

# HD1300XT150

## Lever Assembly and Linkage (con't)

REF. NO.	PART NUMBER	QTY.	DESCRIPTION
1	41500251	1	Fork
2	41500095	1	Linkage, Lever (Diesel)
3	41500241	1	Bracket, Linkage (Diesel)
4	41500065	1	Rod, Linkage (Diesel)
5	41500066	1	Rod, Linkage (Diesel)
6	41500019	3	Rod End
7,8,11,12	41500096	1	Shaft, Lever & Housing Assy.
9	41500043	1	Zerk, Grease
10	41500044	1	Handle
13	41500030	1	Ball, Rocker
14	45000004	3	Nut, Ny-lock 3/8-24
15	41500072	1	Ball, Pivot (Diesel)
16	45000177	1	Bolt, 3/8-16x1" Grade 5
17	45000225	5	Nut, 3/8-24 Grade 5
18	45000064	1	Flat Washer, 3/8"
19	45000012	1	Bolt, 1/4-28x2" Grade 5
20	45000015	1	Lock Nut, 1/4-28
21	45000051	1	Lock Nut, 3/8-16
22	41500175	1	Boot
23	41500164	1	Tool, Spline Alignment
24	41500103	1	Tool, Adjustment
25	45000028	1	Setscrew - 5/16-18
26	45000014	1	Bolt, 1/4-28x1" Long
27	45000103	1	Lockwasher - 9/16"

# HD1300XT150

## Diesel Engine Clutch and Housing

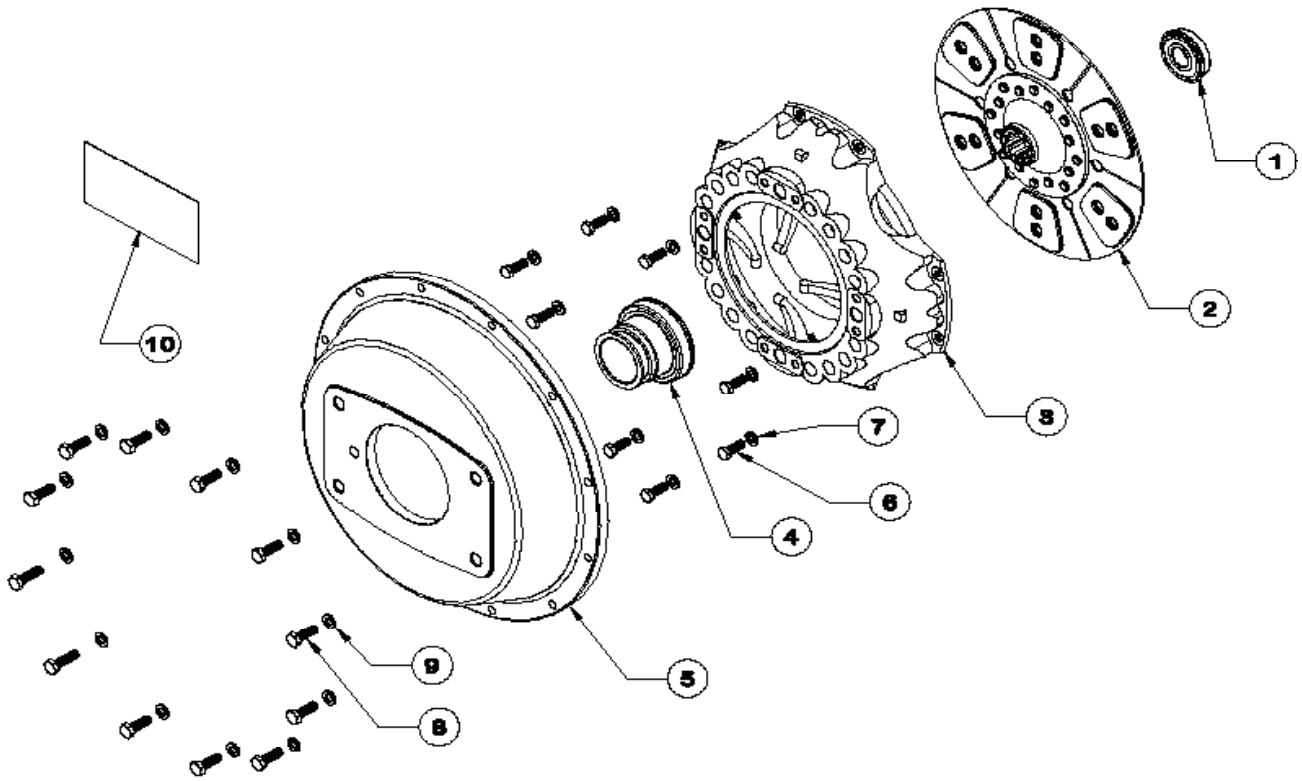

REF. NO.	PART NUMBER	QTY.	DESCRIPTION
1	41500218	1	Pilot Bearing (Perkins, CAT, Cummins)
	41500217	1	Pilot Bearing (John Deere)
2	41500237	1	Disc, Clutch
3	41500209	1	Plate, Clutch Pressure (16 Springs)
4	41500248	1	Bearing, Throw Out
5	41500172	1	Housing, Adapter
6	45000224	8	Bolt, 3/8"-24x1" Grade 5 (Perkins, CAT)
	45000054	8	Bolt, 3/8"-16x1" Grade 5 (John Deere, Cummins)
7	45000063	8	Lock Washer, 3/8"
8	45000043	10	Bolt, M10-1.5x30mm
	45000226	2	Bolt, M10-1.5x35mm (Perkins, CAT, John Deere)
9	45000046	12	Lock Washer, M10
10	41500216	1	Decal, Diesel Clutch

# HD1300XT175

## PTO Assembly, 1.75" Spline

### 2.25" Output Shaft

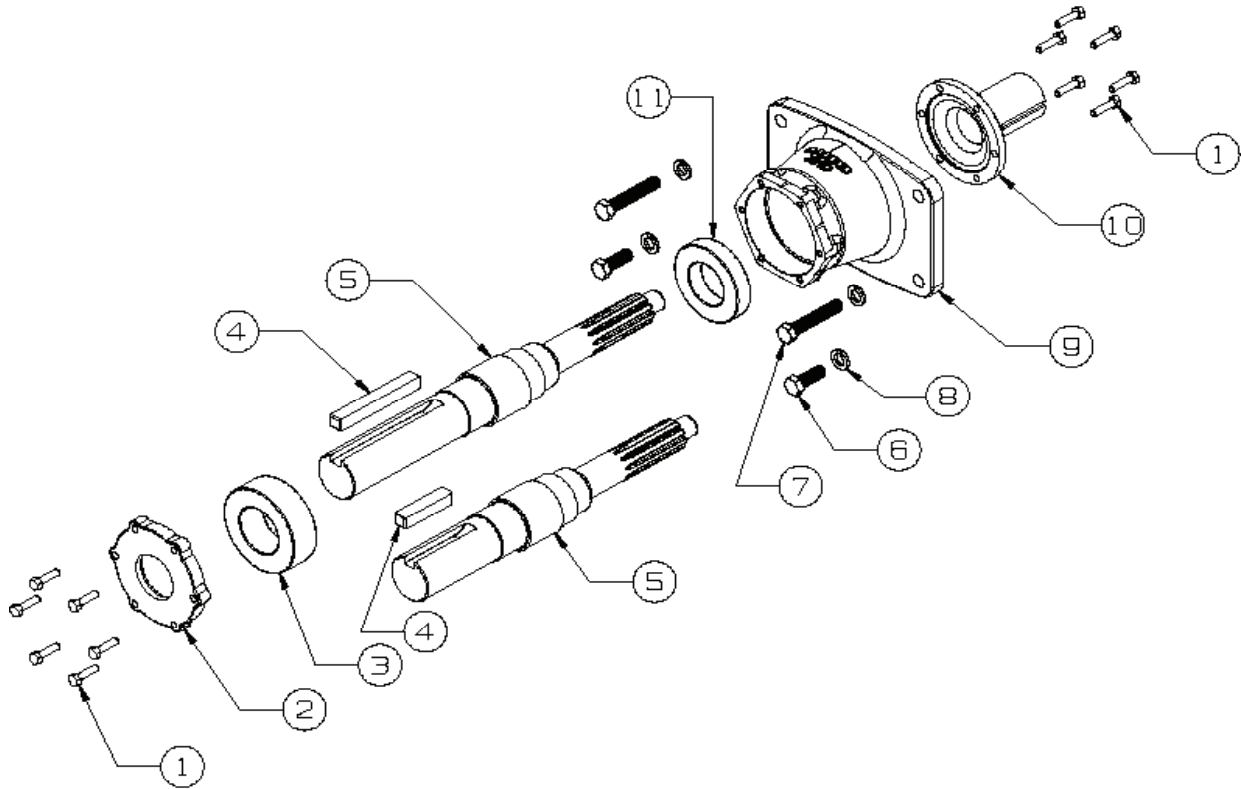

REF. NO.	PART NUMBER	QTY.	DESCRIPTION
1	45000212	12	Bolt, 5/16-18x1 1/4" Grade 5
2	41500205	1	Cover, Rear
3	41500206	1	Bearing, Rear
4	41500126	1	Key, .625 sq. x 5" Long
		1	Key, .625 sq, x 2.25" Long
5	41500246	1	Shaft, PTO Long, (6.56" Tail Shaft)
	41500245	1	Shaft, PTO Short, (4.04" Tail Shaft)
6	45000104	2	Bolt, 9/16-12x1 1/2"
7	45000177	2	Bolt, 9/16-12x3 1/2"
8	45000103	4	Washer, Lock 9/16"
9	41500204	1	Housing, PTO
10	41500242	1	Housing, Bearing Retainer
11	41500207	1	Bearing, Front
	41500243 (Long)	1	Assembly, PTO Shaft & Housing
	41500244 (Short)		(Includes 1,2,3,4,5,9,10, and 11)

# HD1300XT175

## Lever Assembly and Linkage

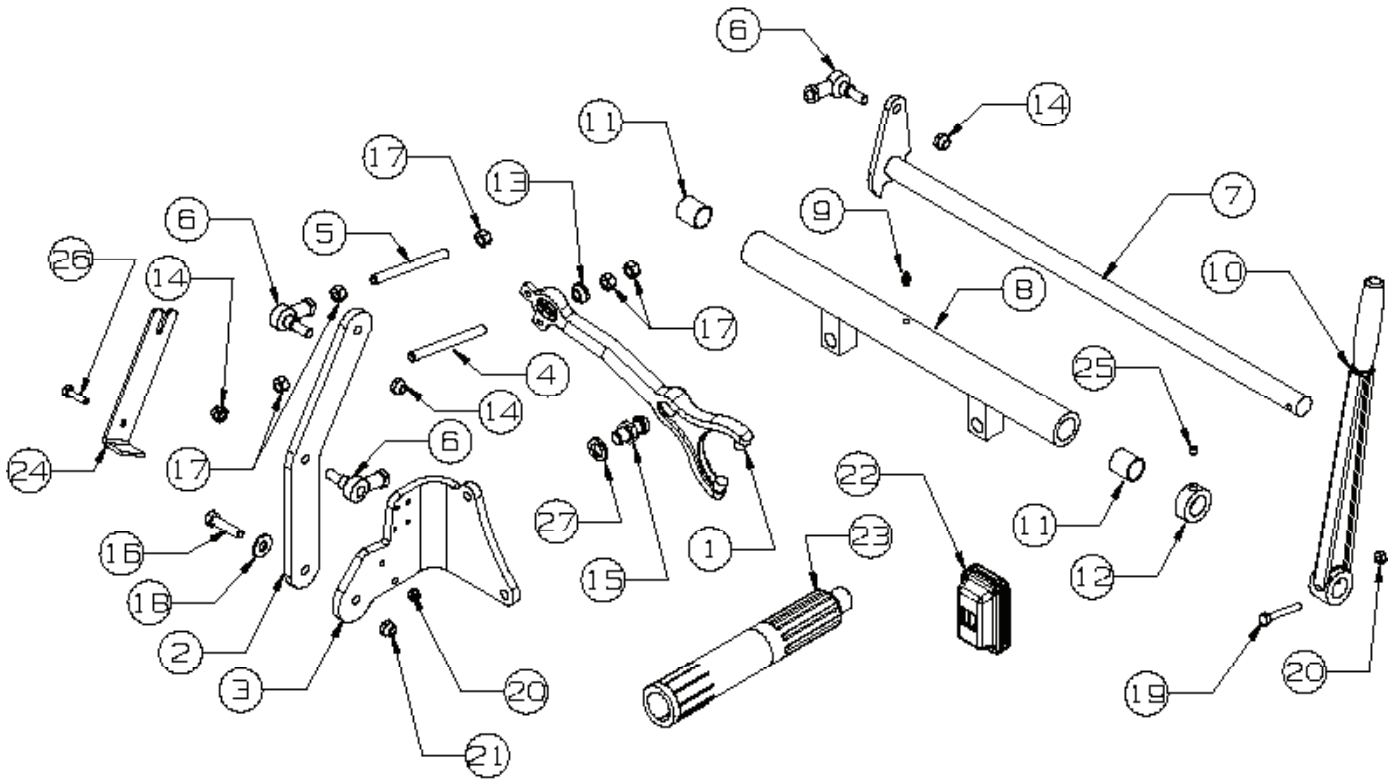

For Parts Breakdown See Next Page

# HD1300T175

## Lever Assembly and Linkage (con't)

REF. NO.	PART NUMBER	QTY.	DESCRIPTION
1	41500251	1	Fork
2	41500095	1	Linkage, Lever (Diesel)
3	41500241	1	Bracket, Linkage (Diesel)
4	41500065	1	Rod, Linkage
5	41500066	1	Rod, Linkage (Diesel)
6	41500019	3	Rod End
7,8,11,12	41500096	1	Shaft, Lever & Housing, Assy.
9	41500043	1	Zerk, Grease
10	41500044	1	Handle
13	41500030	1	Ball, Rocker
14	45000004	3	Nut, Nylock 3/8-24
15	41500072	1	Ball, Pivot (Diesel)
16	45000177	1	Bolt, 3/8-16x1" Grade 5
17	45000225	5	Nut, 3/8-24 Grade 5
18	45000064	1	Flat Washer, 3/8"
19	45000012	1	Bolt, 1/4-28x2" Grade 5
20	45000015	1	Lock Nut, 1/4-28
21	45000051	1	Lock Nut, 3/8-16
22	41500175	1	Boot
23	41500247	1	Tool, Spline Alignment
24	41500103	1	Tool, Adjustment
25	45000028	1	Setscrew - 5/16-18
26	45000014	1	Bolt, 1/4-28x1" Long
27	45000103	1	Lockwasher - 9/16"

# HD1300XT175

## Diesel Engine Clutch and Housing

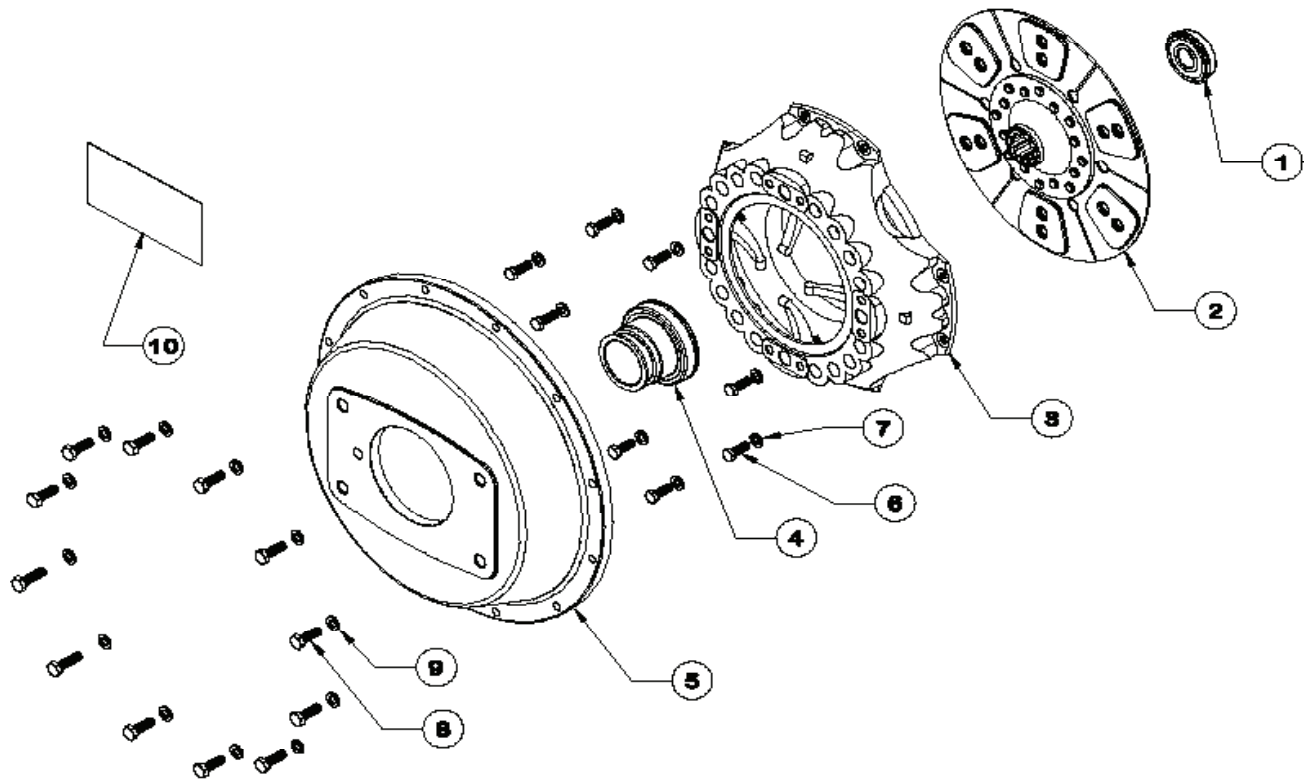

REF. NO.	PART NUMBER	QTY.	DESCRIPTION
1	41500218	1	Pilot Bearing (Perkins, CAT, Cummins)
	41500217	1	Pilot Bearing (John Deere)
2	41500239	1	Disc, Clutch
3	41500209	1	Plate, Clutch Pressure (16 springs)
4	41500248	1	Bearing, Throw Out
5	41500172	1	Housing, Adapter
6	45000224	8	Bolt, 3/8"-24x1" Grade 5 (Perkins, CAT)
	45000054	8	Bolt, 3/8"-16x1" Grade 5 (John Deere, Cummins)
7	45000063	8	Lock Washer, 3/8"
8	45000043	10	Bolt, M10-1.5x30mm
	45000226	2	Bolt, M10-1.5x35mm (Perkins)
9	45000046	12	Lock Washer, M10
10	41500216	1	Decal, Diesel Clutch

# **Auto Clutch PTO and Clutch Components Warranty Statement**

## **PTO Assembly**

AUTO Mfg. Inc. warrants the PTO assembly which it controls the design and fabrication of, to be free from defects in materials and workmanship for a period of **two years** from the date of sale to the original retail purchaser. This warranty is valid provided **AUTO Mfg. Inc.** is notified of the alleged defect within 10 days of its discovery.

## **Clutch Disc, Pressure Plate and Throw-out Bearing**

**AUTO Mfg. Inc.** warrants the clutch disc, pressure plate, and throw out bearing to be free of defects in material and workmanship for a period of **one year** from the date of sale to the original retail purchaser. This warranty is valid provided **AUTO Mfg. Inc.** is notified of the alleged defect within 10 days of its discovery.

**Clutch disc, pressure plate, and throw-out bearing will not be considered for warranty when failure is due in the judgment of AUTO Mfg. Inc. to premature wear out or damage caused by slippage, operator abuse or mis-adjustment.**

## **Method of Obtaining Warranty**

If proven to **our** satisfaction that the product is defective as to material and workmanship, the necessary parts will be replaced and/or repaired by **AUTO Mfg. Inc.** Before starting repair on the PTO assembly, the owner or the service dealer must discuss the repair with the **AUTO Mfg. Inc.** Product Support Manager at 1-800-551-2938. Once it is determined that a possible warranty failure has occurred, the Product Support Manager and the owner or servicing dealer must discuss the method and cost of repair. Replacement components will require the owner or the servicing dealer to purchase replacement parts from **AUTO Mfg. Inc.** The component or part in question must be returned to **AUTO Mfg. Inc. via freight prepaid** to be considered for warranty credit. **AUTO Mfg. Inc.** obligation under this warranty is limited to repair or replacement of AUTO Clutch products or parts only and does not obligate **AUTO Mfg. Inc.** to bear any other cost including economic loss, consequential, incidental or punitive damages. **The sole and exclusive remedy under this warranty shall be the cost of repair or in the discretion of AUTO Mfg. Inc., the replacement of the defective item or items. Maximum allowable labor is 4 hours at \$50.00 per hour. No travel time will be considered.**

## **Other Suppliers Components**

Items manufactured by other suppliers and used by **AUTO Mfg. Inc.** to complete the packaged product are warranted, if at all only by the respective manufacturer. These items typically include, but are not limited to bearings, linkage components, etc. If the owner or servicing dealer is of the opinion that a component should be considered for warranty, **AUTO Mfg. Inc.** Product Support will assist in presenting a warranty claim to the responsible manufacturer. Replacement of any of these components will require the owner or the servicing dealer to purchase the replacement part from **AUTO Mfg. Inc.** The component in question must then be returned to **AUTO Mfg. Inc.** via freight prepaid. The suspect component will then be reviewed by **AUTO Mfg. Inc.** with the responsible supplier for possible warranty credit. **If credit is obtained, a cash credit for the part only will be issued to an owner or a credit memo will be issued to a servicing dealer. The sole and exclusive remedy under this warranty will be the cost of the replacement part only. No labor or travel time will be considered.**

**Under no circumstances will AUTO Mfg. Inc. or any servicing dealer be liable for incidental or consequential damages or injuries including, but not limited to, loss of profits, rental of substitute equipment or other commercial loss, damage of equipment in which the clutch is installed or for damages suffered by purchaser as a result of fundamental breaches of contract or breaches of fundamental terms.** The remedies set forth in this warranty are the purchaser's exclusive remedies in connection with the performance of, or any breach of guaranty, condition, or warranty in respect of **AUTO Mfg. Inc.** clutches.

**AUTO Mfg. Inc.** reserves the right to improve the product through changes in design or materials without being obligated to incorporate such changes in products of prior manufacturer. The customer will not use any such changes as evidence of insufficiency or inadequacy of prior designs or materials.

**THE WARRANTY IN THIS STATEMENT BY AUTO MFG. INC. IS EXPRESSLY IN LIEU OF ALL OTHER WARRANTIES EXPRESSED OR IMPLIED.**

AUTOCLUTCHWARRANTY10/09/08



655 Wheat Lane, Wood Dale, IL 60191  
Phone: 800.456.AUTO (2886) Fax: 800.432.9745