

GIANT-VAC[®]

Municipal

***ASSEMBLY INSTRUCTIONS
SAFETY RULES
PARTS LIST***

TM4901-JDTB Truck Loader

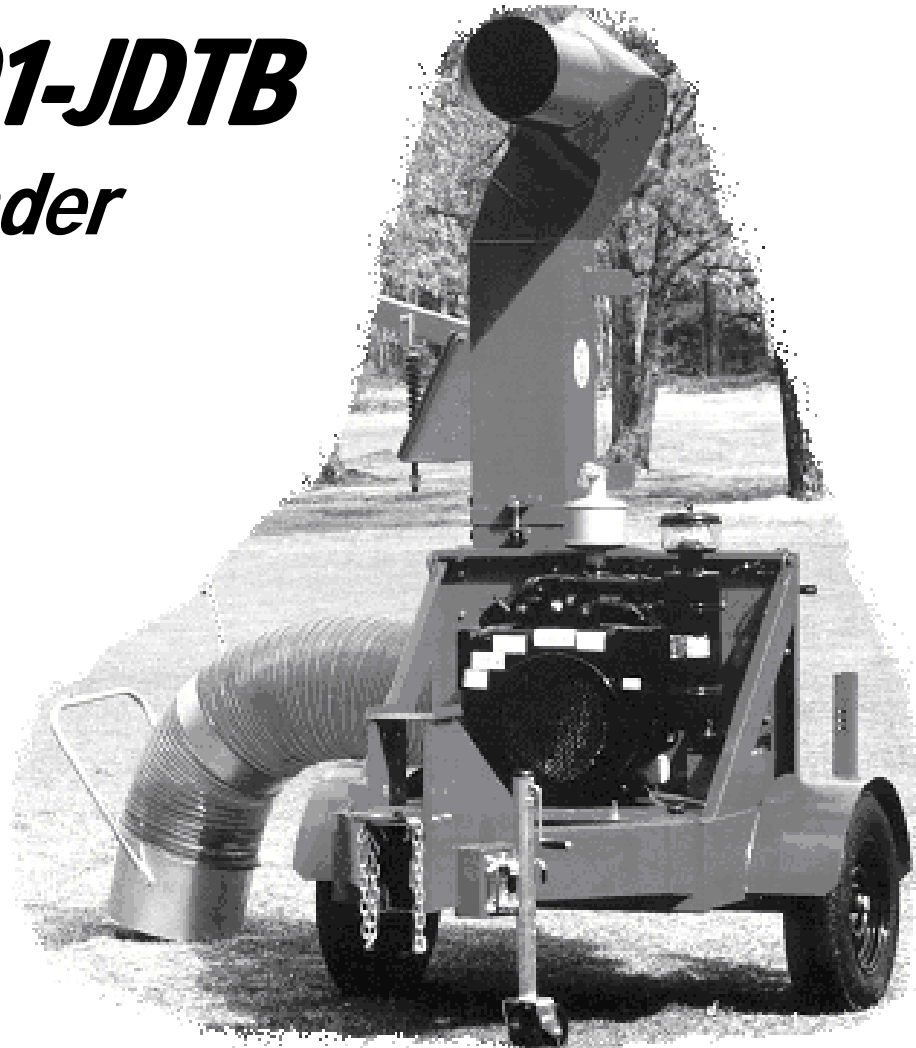

Actual product differs from product pictured above

Models covered:
TM4901JDTB-HW

1 preliminaries

Congratulations!

You have just purchased one of the finest pieces of outdoor power equipment on the market today. If properly cared for, your new truck loader will provide years of dependable service. Please read and follow this instruction manual carefully in order to get the most out of your new equipment.

As you carefully uncrate your unit, you will find the following items:

- 1 Power Unit
- 1 Discharge Stack & Elbow Assembly
- 1 12" x 6' Metal Discharge Hose (standard units)
- 1 16" x 7' Intake Hose (standard units)
- 1 Horizontal Hose Support Boom Member
- 1 Parts Accessory Kit including:
 - 1 – 16" Intake Nozzle
 - 4 – 16" Hose Clamps
 - 1 – Hose Support Boom Horizontal Member
 - 1 – 12" Squeeze Ring
 - 1 – Package of assembly hardware
 - 1 – Package containing operating manuals and warranty registration

Each product leaves our factory in excellent condition; occasionally, however, some damage may occur during shipment. If any such damage is found upon initial inspection, *immediately* notify the transport carrier who delivered your machine, as they are solely responsible for such damage, as well as any subsequent adjustments necessary.

Before assembly, please take a moment and record your model number and serial number below for future reference (both numbers are located on the silver tag adhered to the engine side of the impeller housing assembly):

Model number _____

Serial number _____

Also be sure to promptly fill out and return the warranty registration enclosed in your manual packet.

Your new loader requires very little assembly. Simply follow the instructions contained within this manual to begin enjoying the benefits of your new unit.

CALIFORNIA PROPOSITION 65 WARNING

Gasoline and Diesel engine exhaust and some of its constituents are known to the State of California to cause cancer, birth defects and other reproductive harm.

As an owner of off-road gasoline or diesel engine equipment and/or as an employer, you also may have an obligation under the California Occupational Safety and Health Act or under Proposition 65 to warn persons exposed to gas and diesel engine exhaust and/or other Proposition 65 chemicals in and around your workplace. See California Health and Safety Code section 25249.5, Title 22 of the California Code of Regulations at Section 1200 *et seq.*, and Title 8 of the California Code of Regulations Section 5194.

R0603.1

2

safety rules regarding outdoor power equipment

PLEASE READ THE FOLLOWING BEFORE ASSEMBLING OR OPERATING UNIT

TRAINING

- Read, understand, and follow all instructions in the manual and on the unit before starting. If the operator(s) or mechanic(s) cannot read English it is the owner's responsibility to explain this material to them.
- Become familiar with the safe operation of the equipment, operator controls, and safety signs.
- All operators and mechanics should be trained. The owner is responsible for training the users.
- Only allow responsible adults, who are familiar with the instructions, to operate the unit.
- Never let children or untrained people operate or service the equipment. Local regulations may restrict the age of the operator.
- The owner/user can prevent and is responsible for accidents or injuries occurring to themselves, other people or property.

PREPARATION

- Evaluate the terrain to determine what accessories and attachments are needed to properly and safely perform the job. Use only accessories and attachments approved by the manufacturer.
- Wear appropriate clothing including safety shoes, safety glasses and ear protection. Long hair, loose clothing or jewelry may get tangled in moving parts.
- Inspect the area where the equipment is to be used and remove rocks or any other such objects which can damage the machine or the receiver box.
- Use extra care when handling gasoline and other fuels. They are flammable and vapors are explosive.
 - a) Use only an approved container.
 - b) Never remove fuel cap or add fuel with the engine running. Allow engine to cool before refueling. Do not smoke.
 - c) Never refuel or drain the machine indoors.
- Check that operator's presence controls, safety switches and shields are attached and functioning properly. Do not operate unless they are functioning properly.

OPERATION

- Never run an engine in an enclosed area.
- Operate only in the daylight or with good artificial light, keeping away from holes and hidden hazards.
- Be sure all components are securely in place and in good operating order before starting engine.
- Be sure of your footing while using equipment, especially when backing up. Walk, don't run.
- Do not operate the unit without discharge connected to a debris receiver box.
- Slow down and use caution when making turns and when changing directions on slopes.
- Never leave a running unit unattended. Always stop engine, and remove keys before leaving unit.
- Never operate without guards securely in place. Be sure all safety features are attached, adjusted properly and functioning properly.
- Never operate with intake or discharge components loose, removed or altered.
- Do not change the engine governor setting or over speed the engine.
- Stop on level ground, shut off engine before leaving the operator's position for any reason including emptying the receiver box or unclogging the intake or discharge.
- Stop equipment and inspect impeller blades after picking up unusually large or hard objects or abnormal vibration occurs. Make necessary repairs before resuming operations.
- Keep hands and feet away from the intake and discharge.
- Never carry passengers and keep pets and bystanders away.
- Do not operate the unit while under the influence of alcohol or drugs.
- Slow down and use caution when making turns and crossing roads and sidewalks.
- Use care when hooking or unhooking the machine to a towing vehicle.
- Use care when approaching blind corners, shrubs, trees or other objects that may obscure vision.

2

safety rules regarding outdoor power equipment (cont.)

SLOPE OPERATION

Slopes are a major factor related to loss-of-control and tip-over accidents, which can result in severe injury or death. All slopes require extra caution. If you cannot back up the slope, or if you feel uneasy on it, do not operate on it.

Do

- Remove obstacles such as rocks, tree limbs, etc.
- Watch for holes, ruts, or bumps. Uneven terrain could overturn the unit. Tall grass can hide obstacles.
- Use slow speed.
- Keep all movement on the slopes slow and gradual. Do not make sudden changes in speed or direction.

Do Not

- Do not start or stop on a slope. If tires lose traction, stop the unit and proceed slowly straight down the slope.
- Do not turn on slopes unless necessary, and then, turn slowly and gradually downhill, if possible.
- Do not operate near drop-offs, ditches, or embankments. The operator could lose footing or balance or unit could suddenly turn over if a wheel is over the edge of a cliff or ditch, or if an edge caves in.

CHILDREN

Tragic accidents can occur if the operator is not alert to the presence of children. Children are often attracted to the unit and its activity. Never assume that children will remain where you last saw them.

- Keep children out of the operating area and under the watchful care of another responsible adult.
- Be alert and turn unit off if children enter the area.
- Before and during reverse operation, look behind and down for small children.
- Never carry children. They may fall off and be seriously injured or interfere with safe unit operation.
- Never allow children to operate the unit.
- Use extra care when approaching blind corners, shrubs, trees, or other objects that may obscure vision.

EMISSIONS

- Engine exhaust from this product contains chemicals known, in certain quantities, to cause cancer, birth defects, or other reproductive harm.
- Look for the relevant Emissions Durability Period and Air Index information on the engine emissions label.

MAINTENANCE AND STORAGE

- Always observe safe refueling and fuel handling practices when refueling the unit after transportation or storage.
- Always follow the engine manual instructions for storage preparations before storing the unit for both short and long term periods.
- Always follow the engine manual instructions for proper start-up procedures when returning the unit to service.
- Never store the machine or fuel container inside where there is an open flame, such as in a water heater. Allow unit to cool before storing.
- Shut off fuel while storing or transporting. Do not store fuel near flames or drain indoors.
- Keep all hardware, especially impeller bolt, tight and keep all parts in good working condition. Replace all worn or damaged decals.
- Never tamper with safety devices. Check their proper operation regularly.
- Clean debris from units, drives, mufflers, and engine to prevent fires. Clean up oil or fuel spillage.
- Stop and inspect the equipment if you strike an object. Repair, if necessary, before restarting.
- Never make adjustments or repairs with the engine running unless specified otherwise.
- Park machine on level ground. Never allow untrained personnel to service machine.
- Use jack stands to support components when required.
- Carefully release pressure from components with stored energy. (e.g. springs)
- Check impeller on a regular basis for bent, worn or cracked blades. Only replace impellers; never straighten or weld them.
- Keep hands and feet away from moving parts.

2 *safety rules regarding outdoor power equipment (cont.)*

- Belts and belt guard components are subject to wear, damage, and deterioration, which could expose moving parts or allow objects to be thrown. Frequently check components and replace with manufacturer's recommended parts, when necessary.
- Check operation of brake, tail and license lights frequently. Replace as required.
- Use only factory authorized replacement parts when making repairs.
- Always comply with factory specifications on all settings and adjustments.
- Only authorized service locations should be utilized for major service and repair requirements.
- Never attempt to make major repairs on this unit unless you have been properly trained. Improper service procedures can result in hazardous operation, equipment damage and voiding of manufacturer's warranty.

3 *unit assembly & set-up*

Note: Please refer to Parts List for correct part identification and placement. Parts list reference numbers are called out by sheet number followed by reference number(s) on that sheet: (1:1) indicates Sheet 1, reference number 1; (2:32,34-38) indicates Sheet 2, reference numbers 32 through 38 excluding 33; etc.



Important Safety Note: To prevent unit rollover during assembly and set up, lock rear support leg in lowermost position possible. Failure to do this may result in injury or death and/or damage to unit or property.

DISCHARGE ASSEMBLY

Safety Note: Assistance is required when installing discharge stack. If access to lifting equipment is possible, it is highly recommended.

- Place stack & elbow assembly (5:1) atop power unit, with discharge directed toward towing hitch. Insert twelve 1/2-13 x 1-3/4" hex bolts (5:2), each fitted with one flat washer (5:3), through bolt flange holes, securing with flat washers, lock washers and nuts (5:3-5). Tighten securely.

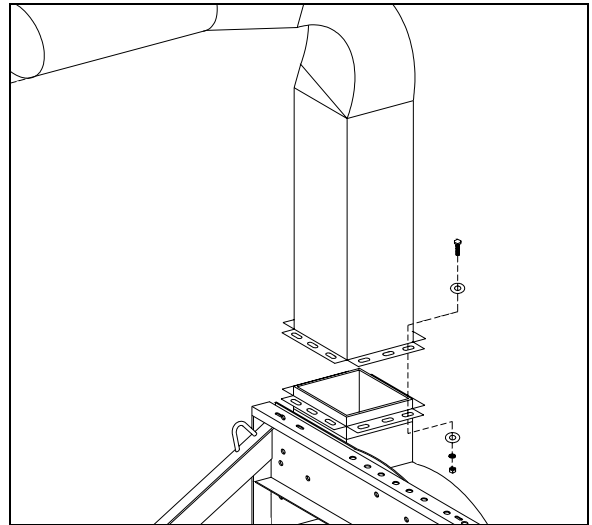

3 *unit assembly & set-up (cont.)*

- Slip one end of metal discharge hose (5:6) onto barrel of discharge stack.
- Secure hose in place with squeeze ring (5:7), tightening all bolts securely enough to dimple hose against barrel of stack and thereby prevent slippage of hose on stack assembly.

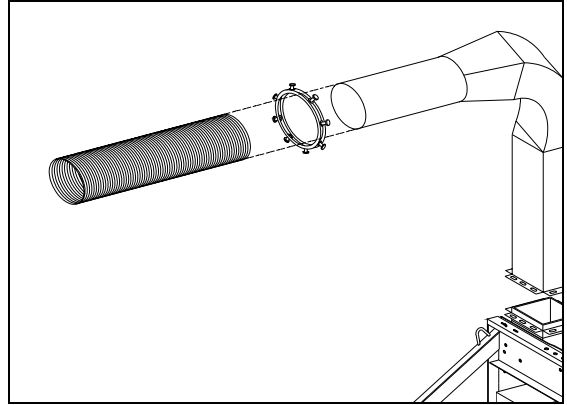

INTAKE ASSEMBLY

- Slip two hose clamps (4:9) onto one end of intake hose (4:8), then slip end of hose onto intake flange barrel (4:5), located in front of impeller housing. Tighten clamps securely.
- Slip Hose support band (4:10) about halfway up the length of the hose, with eye clip facing up.
- Slip two hose clamps onto free end of intake hose, followed by Intake Nozzle (4:11) with handle pointed upwards and toward hose. Tighten clamps securely.

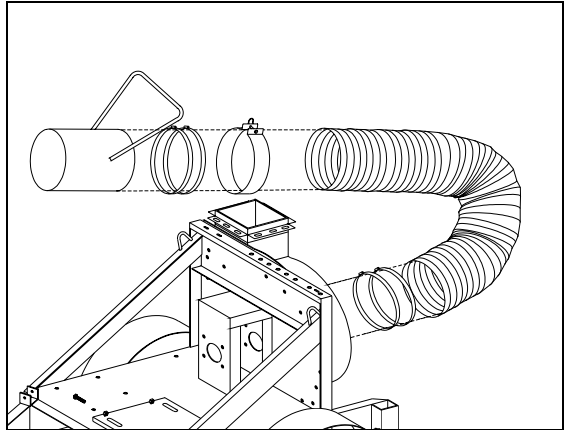

HOSE SUPPORT BOOM ASSEMBLY

- Attach yoke end of Threaded spring guide (6:5) to second thru hole of horizontal boom member (6:2) with one 1/2-13 x 3" hex bolt (6:3), securing with 1/2-13 lock nut (6:4). Do not over tighten lock nut. Note: Be sure spring guide and chain eye at end of boom are both toward bottom of boom member.
- Attach horizontal boom member to vertical boom member (6:1) with one 1/2-13 x 3" hex bolt, securing with 1/2-13 lock nut. Do not over tighten lock nut. Be sure spring guide is toward base of vertical boom member.
- Remove 3/4" hex nut and flat washer (6:6-7) from bottom of threaded spring guide. Slip thread down through hole in base of vertical boom member, securing with same hardware as previously removed.

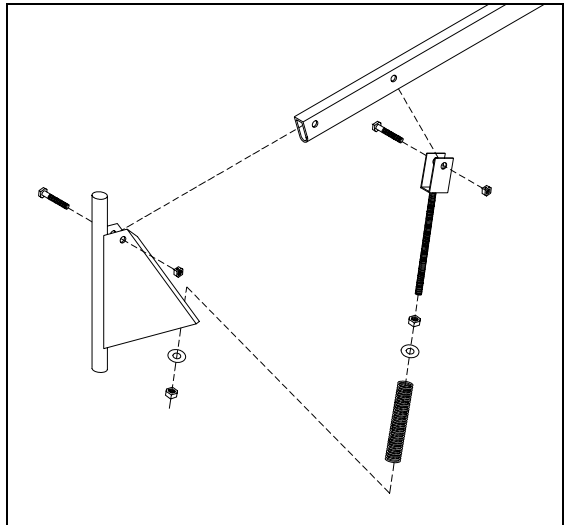

3 *unit assembly & set-up (cont.)*

HOSE SUPPORT BOOM ASSEMBLY (cont.)

- Lift assembly and install into boom pivot brackets on discharge stack, first slipping top portion of vertical boom member into top bracket on stack, then dropping bottom portion into bottom bracket.

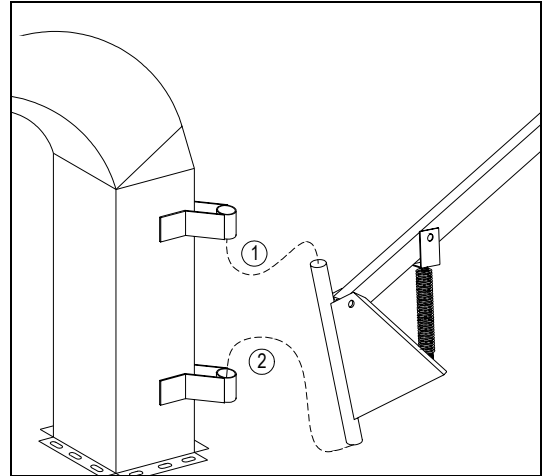

- Catch S-hook on one end of boom support chain (6:9) into chain eye at end of horizontal boom member.
- Slip other end of chain through eye clip atop hose support band, then adjust chain length between hose and boom to about three feet (3/4 of total length) by slipping S-hook on end of chain through appropriate mid-link.

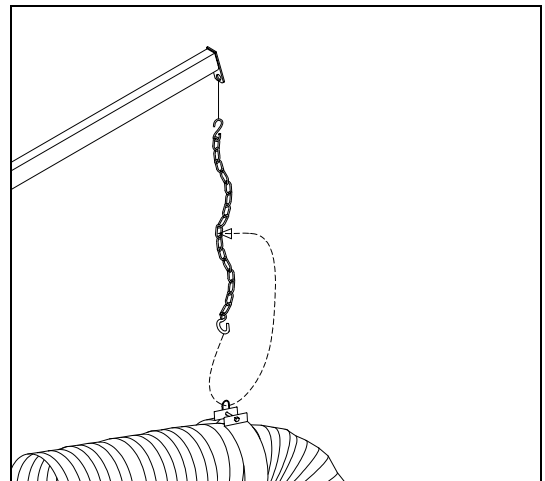

3 *unit assembly & set-up (cont.)*

DEBRIS BOX CONSTRUCTION



WARNING: This unit is designed to be used in conjunction with a debris collection box. **NEVER** run or operate your Truck Loader without a debris box.

Below are directions for constructing a simple, sturdy debris box for use in a standard pickup bed:

- Cut four pieces of 3" angle iron to the inside length of the truck bed, four pieces to the inside width, then four pieces that measure from the truck bed floor to approximately 8" higher than the top of the unit discharge when the unit is connected to the truck. Either weld or securely bolt the box frame together.
- Line the inside front and sides with 3/4" exterior grade plywood.
- Cover the top of the frame with a heavy-duty mesh screening to allow for adequate ventilation.
- Cut a plywood door the width and height of the box frame. Install a heavy-duty hinge at the top of the door and fasten it to the rear of the box frame. Install latches or other locking mechanisms between the lower sides of the door and the box sides to keep the door from opening inadvertently.
- Mark the location on the door where the unit discharge meets the box, then cut a 16" diameter hole in the door at that location. Install a rubber gasket around the hole to prevent debris blow-by – an old 13" or 14" inner tube works fine.

CONNECTING UNIT TO TOWING VEHICLE

- Install appropriate trailer plug onto end of unit wiring harness to match socket on towing vehicle. Wiring scheme is as follows:

Red – Right signal
Yellow – Left signal
Brown – Taillights
Green – Ground

- Raise or lower support jack until unit sits level with ground. Back towing vehicle up to draw bar, then visually check draw bar for proper height alignment with hitch receiver on vehicle. Raise or lower draw bar if needed by relocating in any of the remaining sets of height adjustment holes.
- With assistance behind, back up slowly, aligning both draw bar with hitch receiver and discharge hose with receiver box opening.
- Lock pintle ring in hitch receiver, connect safety chains to vehicle in a criss-cross fashion to cradle draw bar in case of accidental disconnect, then connect wiring harness plug into trailer socket of vehicle.
- Lift rear support leg and pin in uppermost position.



Note: To prevent possible rollover, lock rear support leg in lowermost position possible when unit is parked or disconnected from towing vehicle.

Your unit is now ready to be started and checked for proper operation. See your engine manual for proper engine prep and operation.

4 *unit operation*

GENERAL GUIDELINES TO OBSERVE DURING OPERATION

- Never allow a person to ride, sit or stand on the unit. Never allow a person to ride, sit or stand on the towing vehicle other than in the driver's cab of the towing vehicle.
- Make sure that the driver of the towing vehicle has the operator of the unit in full view at all times. Also, when operating the unit, instruct the operator to stay to the side of the machine, never in front or behind.
- Collecting debris into piles for the machine to intercept prior to startup will save time and fuel as well as wear and tear on the unit.
- We recommend the following for the most efficient performance: if debris is very dry, run the machine at approximately half throttle; this will help reduce the amount of small particles of debris escaping through the ventilation screen. If debris is wet or partially frozen, run the machine at full throttle.
- Lower intake hose boom assembly until nozzle floats 2-3 inches from the ground, then adjust engine throttle so that when nozzle is pushed to the ground, suction can be broken with moderate effort using three fingers of one hand. This will make operation relatively easy and comfortable.
- Time and experience will be your best guide in finding the most efficient performance from your unit.

UNCOUPLING UNIT FROM TOWING VEHICLE

- Disconnect taillight/brake light plug from towing vehicle receiver.
- Unhook safety chains from rear of towing vehicle.
- Crank down wheel jack until unit weight is lifted from towing vehicle.
- Drop rear support leg to lowermost position and secure with clevis and bridge pin. **Note: Failure to follow this step can result in unit rollover and serious personal injury and unit damage.**
- Open pintle receiver latch on towing vehicle, determine if pintle ring on unit will clear pintle receiver on vehicle (crank down wheel jack an additional turn or two if not), and pull vehicle away.

5 *unit maintenance*

GENERAL MAINTENANCE

NOTE: Some maintenance services, such as engine repairs, electrical repairs, etc., should be performed only by a qualified technician.

- Check overall condition of unit prior to each use, repairing or replacing worn, damaged or missing components promptly. Check all fasteners regularly and tighten if necessary.
- Follow engine manufacturer's recommendations for maintenance schedules. Use only recommended parts, fluids and lubricants. Failure to follow manufacturer's recommendations may void manufacturer's warranties.
- Lubricate impeller shaft bearings every 50 hours of operation. Use a high quality bearing grease, available from your local dealer (or auto parts store).
- Maintain tire pressure as indicated on tire sidewall. Replace worn or damaged tires promptly.
- Keep engine free from a buildup of grass, leaves or excessive grease. An accumulation of these combustible materials may result in a fire, or simply impede performance.
- Never change attachments or make any adjustments, repairs or replacements until the unit is completely shut down and the battery is disconnected.

CHECKING AND ADJUSTING IMPELLER BELTS

NOTE: Check new belts frequently during first 24-48 hours of installation, as tension will decrease significantly due to belt seating.

To obtain optimum performance and longer life from your belts, check and adjust belt tension using a belt tension checker, available at any auto parts dealer.

- Remove drive belt top cover.
- Take an initial tension check. Good belt tension is generally between 8-10 lbs. with a 3/8" deflection.
- If adjustment is needed, loosen the four engine mounting bolts. **Do not completely remove bolts.**
- Loosen the two threaded tensioning rods opposite the impeller side of the engine, **making sure to loosen both the same number of turns in order to avoid misaligning the engine.**
- Increase belt tension by slowly tightening the two threaded tensioning rods on the impeller side of the engine, making sure to tighten both the same number of turns in order to avoid misaligning the engine. Recheck tension every turn or so until desired tension is achieved.

5 *unit maintenance (cont.)*

CHECKING AND ADJUSTING IMPELLER BELTS (cont.)

- Retighten engine-mounting bolts securely, then check and tighten all tensioning rods to avoid loosening and consequential loss.
- Replace drive belt top cover.

REPLACING IMPELLER BELTS



IMPORTANT NOTE: IT IS HIGHLY RECOMMENDED THAT IMPELLER BELTS BE REPLACED BY AN AUTHORIZED GIANT-VAC DEALER.

STORAGE

- Keep the unit in locked storage to prevent unauthorized individuals, especially children, from playing and/or tampering with the unit.
- When storing the unit for prolonged periods, it is recommended to disconnect the battery.
- Store fuel in an approved, clearly marked container.
- NO NOT store gasoline powered equipment or fuel containers in any closed area where heat-radiating appliances or open pilot lights are present, unless the fuel has been completely drained from the power equipment and the fuel containers.

REPLACEMENT PARTS

Replacement parts are available from your local Giant-Vac dealer.

LOFA MC704 and MC704 G4 Operation and Troubleshooting

Operation

Turning the control system key to the run position starts a self-test which causes all LED's to flash three times, activates the alarm output (if preheat is not used) for one second and enables the fuel run/stop solenoid output. After self-test, the LED's indicate the state of the inputs they monitor. The normal indications are battery charge and oil pressure on most applications. If these LED's are not illuminated at this time it may indicate the inputs are not properly connected.

The Preheat/OK LED begins to blink when the key switch is turned to the run position if automatic preheat is configured (See Preheat Options). Preheat time varies from application to application. After waiting for the Preheat/OK LED to become solid, the engine is cranked by turning and holding the key switch in the start position until the engine starts. The key switch is spring loaded to return automatically to the run position when released.

Note

The key switch is equipped with a mechanical start locking device. An attempt to re-crank the engine can only be made by turning the key switch to the off position to reset the start locking mechanism.

If the engine is not started within 30 seconds of turning on the system, the fuel run/stop solenoid output is turned off to prevent battery discharge when the key switch is left in the run position. The fuel run/stop solenoid output is turned off after 30 seconds even if preheating. As soon as the key switch is turned to the start position the solenoid output is enabled. The afterglow cycle begins when the key switch returns to the run position.

Note

If conditions do not warrant preheat, the engine may be started by turning the key to the start position without waiting for the preheat time to expire.

Control system instrument power, including the hour meter and voltmeter, is provided by the fuel run/stop solenoid output. If the instruments do not power up when the key is turned to the run position, this indicates a problem with the solenoid circuit (see Troubleshooting).

After the engine starts, the control system electronics ignore all shutdown conditions for the first 10 seconds. This delay eliminates the requirement to hold a by pass override button during starting and allows the system conditions such as oil pressure to normalize. The 10 second timer starts when the key switch returns to the run position.

Note

Starter input is required for correct system operation. If the starter motor input is not activated (connected to battery positive) and the engine is started through another means (i.e. air starter) the engine will shutdown 30 seconds after the key switch is turned to the run position.

To prevent unintentional engine shutdowns caused by intermittent conditions (i.e., pressure spikes, coolant movement) the control system requires a constant 1/3 second fault input to cause engine shutdown.

Warning

When used in combination with mechanical float type switches engine vibrations may prevent constant contact closure.

Preheat Options

Preheat Output

Preheat is a 3A positive output for control of an external power relay with predetermined preheat and afterglow times. A relay should be selected with appropriate amperage capacity for the installed cold start aid (glowplug, intake air heater, etc.). Applications using multiple cold starting aids may require multiple relays.

Note

Consult engine documentation when selecting cold starting aid, power relay and heating specifications.

Indicators

Battery LED (Red)

A solidly illuminated Battery LED indicates a battery charge failure. A battery charge failure may be caused by a faulty alternator, broken drive belt or the alternator not excited. A battery voltage reading of approximately 14 volts on a 12 volt system (28 volts on a 24 volt system) while the engine is running indicates the battery is charging properly. Irregular blinking of the Battery LED may indicate a failing charge circuit. The system can be configured for battery charge failure to indicate only.

Oil Pressure LED (Red)

A solidly illuminated Oil Pressure LED indicates low oil pressure failure. The control system typically senses low oil pressure from a ground contact switch on the engine. When a sender/switch combination is used on the engine, the marking *WK* generally indicates the switch terminal. This input typically expects a normally closed switch (ground contact when oil pressure is low). A defective switch or shorting the shutdown input to ground can cause low pressure fault indication. Additionally, when using sender/switch combinations, swapping the *WK* and *G* terminal can cause unintended shutdowns. The system can be configured for oil pressure failure to indicate only.

Warning

Low oil pressure is not an indication of low oil level

For best possible protection LOFA recommends using our solid-state oil level shutdown switch.

Note

Most shutdown switches are grounded through the switch body.
Do not use insulating sealant (i.e. Teflon tape) when installing switches.

Temperature LED (Red)

A solidly illuminated Temperature LED indicates high engine temperature failure. The control system typically senses high temperature from a ground contact switch on the engine. When a sender/switch combination is used on the engine, the marking *WK* or *W* generally indicates the switch terminal. This input typically expects a normally open switch (ground contact when engine temperature is too high). A defective switch or shorting the shutdown input to ground can cause over temperature fault indication. Additionally, when using sender/switch combinations, swapping the *WK* or *W* and *G* terminal can cause unintended shutdowns. The system can be configured for temperature failure to indicate only.

LOFA MC704 and MC704 G4 Operation and Troubleshooting

Warning

If the temperature switch is not in contact with coolant due to coolant loss the engine is not protected from overheating.

For best possible protection LOFA recommends using our solid-state oil level shutdown switch.

Note

Most shutdown switches are grounded through the switch body. Do not use insulating sealant (i.e. Teflon tape) when installing switches.

Some thermostat housings are composites and do not provide ground for the switch.

AUX LED (Red)

A solidly illuminated AUX LED indicates an auxiliary failure (i.e. coolant level, oil level, belt breakage, hydraulic pressure, etc.). The control system typically senses failure using a ground contact switch. Auxiliary inputs are equipment specific and determined by the equipment manufacturer. A defective switch or shorting the shutdown input to ground can cause fault indications. The system can be configured for auxiliary failure to indicate only.

Preheat/OK LED (Green)

A blinking green Preheat/OK LED is the system preheat indication. When the LED changes to solid the preheat period is complete and the engine may be cranked. The LED changes to solid illumination when the engine starts. There is no indication of afterglow.

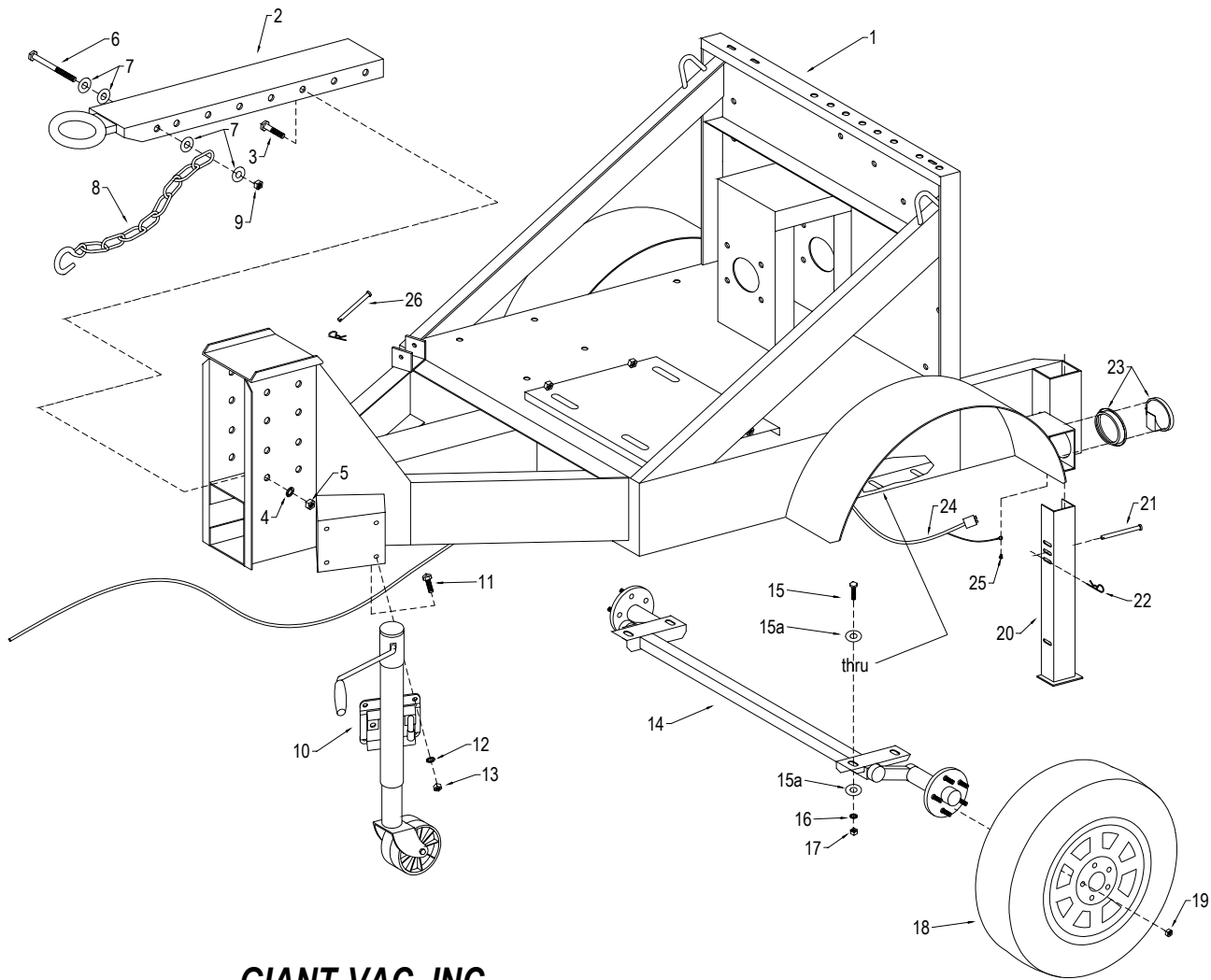

GIANT-VAC, INC.

Model TM4201PDB

Sheet 1 of 6

Trailer Group

R0603.1

Giant-Vac Model TM4901JDB Truck Loader

R0603.1

SHEET 1 - TRAILER GROUP

REF #	PART #	DESCRIPTION	QTY
1	10241	Engine base and trailer frame	1
2	38004	Draw bar	1
3	31084	Bolt, hex - 1/2-13 x 1-1/4"	4
4	31078	Washer, lock - 1/2	4
5	31022	Nut, lock - 1/2-13	4
6	31821	Bolt, hex - 1/2-13 x 7	1
7	31043	Washer, flat - 1/2	4
8	31641	Chain, safety towing	2
9	31406	Nut, lock - 1/2-13	1
10	33173	Jack, dual wheel support	1
11	31033	Bolt, hex - 3/8-16 x 1"	4
12	31008	Washer, lock - 3/8	4
13	31009	Nut, lock - 3/8-16	4
14	33297	Axle, Torflex	1
15	32154	Bolt, hex, black oxide, 1/2-13 x 1-1/4 gr 5	4
15a	32155	Washer, flat, 1/2"	8
16	31084	Washer, lock - 1/2"	4
17	32156	Nut, hex end lock - 1/2-13	4
18	33051	Tire and wheel assy	2
19	31148	Lug nut	10
20	40105	Leg, support	1
21	31125	Pin, clevis - 3/8 x 4-1/2"	1
22	31126	Pin, bridge	1
23	31339	Light, tail/stop assy	2
---	31751	Light, license	1
---	31752	Bracket, license	1
---	31444	Bolt, hex - 1/4-20 x 1 - bolts license light assy to frame	2
---	31013	Washer, lock - 1/4"	2
---	31030	Nut, hex - 1/4-20	2
24	31822	Harness, wiring	1
---	31644	Clip, wiring harness, slip-on - large	10
---	32012	Clip, wiring harness, bolt-on - 3/8" nom	2
---	31562	Screw, self-tapping - #12 x 3/4 (secures bolt-on clips to frame)	2
25	32090	Screw, self-tapping - #10 x 1/2 (taillight ground)	2
26	31125	Pin, clevis - 3/8 x 4-1/2"	1
27	31126	Pin, bridge	1

GIANT-VAC, INC.

Model TM4201PDB

Sheet 2 of 6

Engine Group

R0603.1

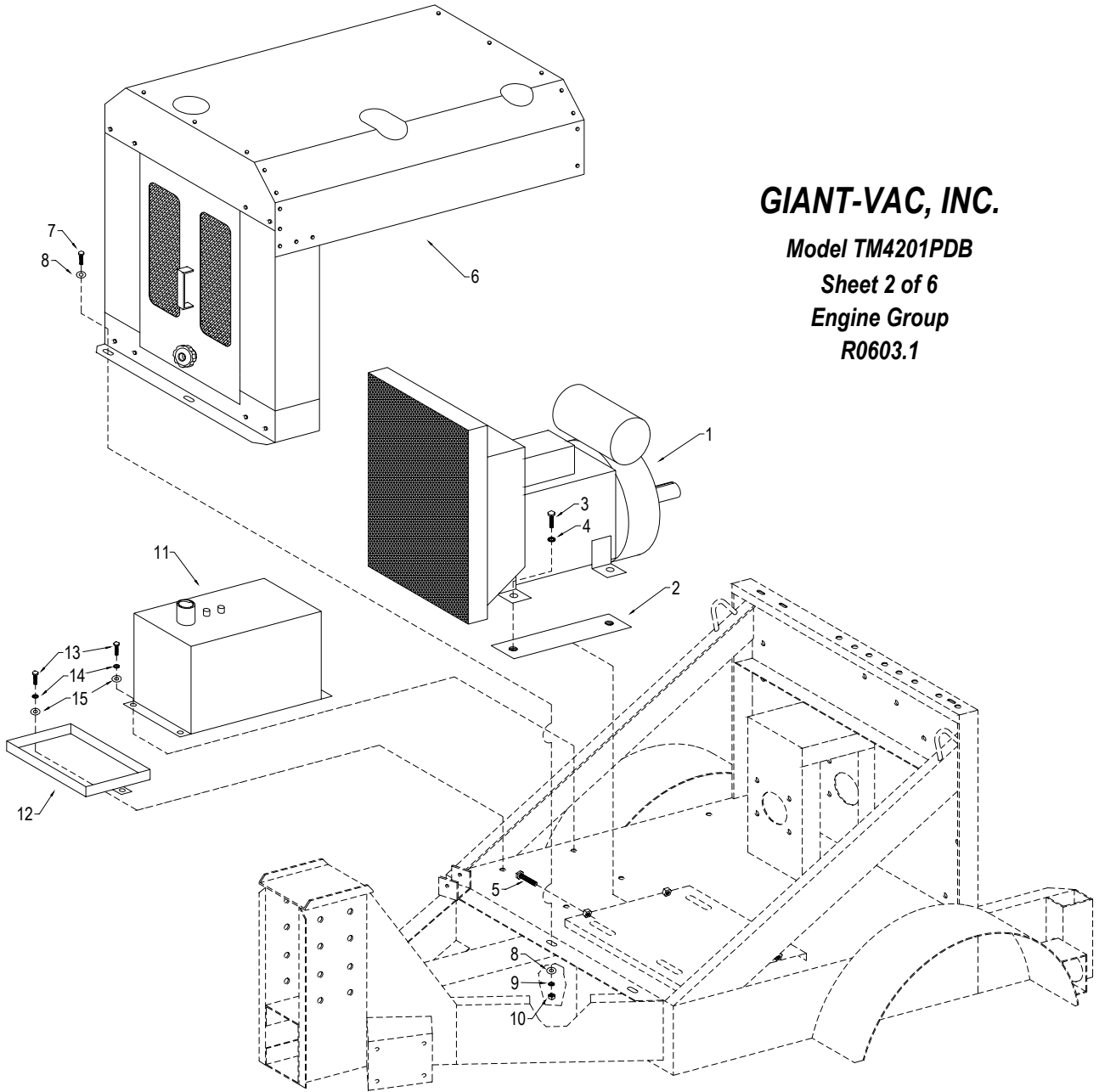

Giant-Vac Model TM4901JDB Truck Loader

R0603.1

SHEET 2 - ENGINE GROUP

REF #	PART #	DESCRIPTION	QTY
1	39064	Engine – 49hp John Deere Tier III Turbo Diesel	1
---	32037	Hose, oil drain extension	1
---	31761	Plug, drain – 1/4" ipt – caps end of oil drain extension hose	1
---	27398	Box, control panel mounting	1
---	27435	Bracket, mounting – control panel side	1
---	27434	Bracket, mounting – machine side	1
---	31033	Bolt, hex - 3/8-16 x 1" – bolts box to mounting brackets	4
---	31008	Washer, lock - 3/8	4
---	31009	Nut, hex - 3/8-16	4
2	27397	Engine mount nut plate	2
3	31147	Bolt, hex - 1/2-13 x 1-1/2"	4
4	31078	Washer, lock - 1/2"	4
5	31880	Bolt, Engine adjustment	4
6	39100	Engine shroud - complete	1
7	31033	Bolt, hex - 3/8-16 x 1"	2
8	31034	Washer, flat – 3/8"	2
9	31008	Washer, lock - 3/8"	2
10	31009	Nut, hex - 3/8-16	2
---	31031	Bolt, hex head – 5/16-18 x 3/4" – mounts shroud rear to frame	4
---	31027	Washer, flat – 5/16"	4
---	31003	Washer, lock – 5/16"	4
---	31004	Nut, hex – 5/16"	4
11	40182	Tank, fuel (2009 EPA)	1
---	40173	Cap, fuel (2009 EPA)	1
---	31830	Plug, drain - 3/8" IPT	1
---	31828	Fitting - 1/4" IPT to 1/4" Farrell	1
---	31829	Fitting - 3/8" IPT to 5/16" Farrell	1
---	31753	Line, copper fuel - 1/4" - 6"	1
---	31754	Line, copper fuel - 5/16" - 14"	1
---	31755	Hose, rubber fuel - 1/4" - 42"	1
---	31756	Hose, rubber fuel - 5/16" - 6"	1
---	31756	Hose, rubber fuel - 5/16" - 12"	1
---	34041	Clamp, hose - 1/2"	6
12	40141	Box, battery mounting	1
---	39021	Battery	1
---	39101	Battery case	1
---	31826	Battery cable - positive - 48S	1
---	31763	Battery cable - ground - 16S	1
---	31838	Cover, battery terminal – red	1
---	31839	Cover, battery terminal - black	1
13	31097	Bolt, hex - 3/8-16 x 1-1/4	2
14	31008	Washer, lock - 3/8	2
15	31034	Washer, flat - 3/8	2

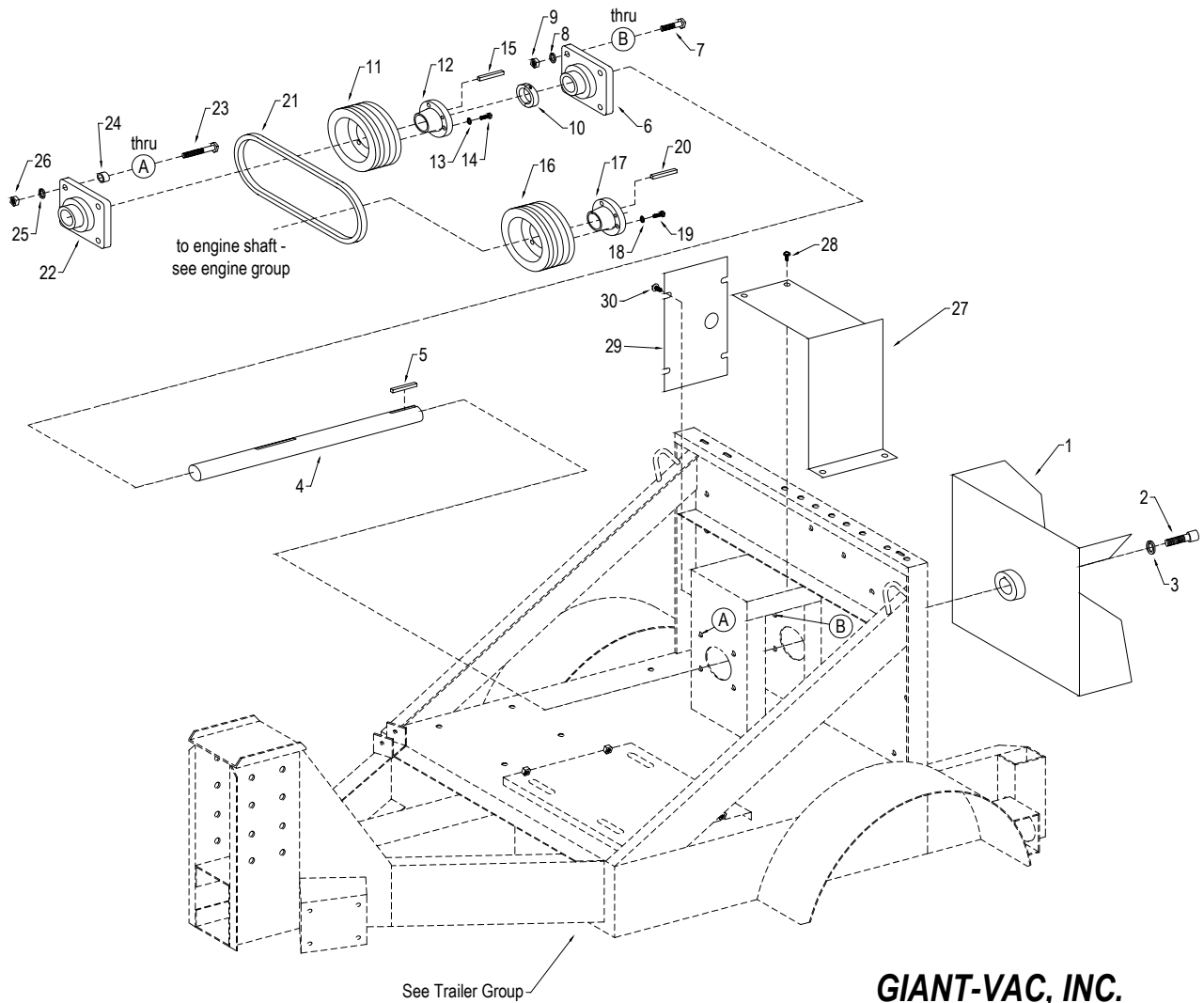

GIANT-VAC, INC.

Model TM4201PDB

Sheet 3 of 6

Impeller Drive Group

R0603.1

Giant-Vac Model TM4901JDB Truck Loader

R0603.1

SHEET 3 - IMPELLER DRIVE GROUP

REF #	PART #	DESCRIPTION	QTY
1	21518	Impeller	1
2	31327	Bolt, impeller – 5/8-11 x 2	1
3	31326	Washer, lock - 5/8"	1
4	36196	Shaft, impeller	1
5	31127	Key, impeller	1
6	36163	Bearing unit - 1-7/16	1
7	31147	Bolt, hex - 1/2-13 x 1-1/2"	4
8	31078	Washer, lock - 1/2"	4
9	31022	Nut, hex - 1/2-13	4
10	31711	Collar, split, 2 pc - 1-7/16	2
11	36296	Pulley, impeller drive	1
12	36340	Bushing, pulley - SKX1-7/16	1
13	-----	Washer, lock – 5/16 – supplied with bushing	3
14	-----	Bolt, hex – 5/16-18 x 2" full thread – supplied with bushing	3
15	31677	Key, shaft	1
16	36296	Pulley, impeller drive	1
17	36341	Bushing, pulley - SKX1-3/4	1
18	-----	Washer, lock – 5/16 – supplied with bushing	3
19	-----	Bolt, hex – 5/16-18 x 2" full thread – supplied with bushing	3
20	31677	Key, shaft	1
21	36334	Belt, impeller drive - 3VX475	5
22	36163	Bearing unit - 1-7/16	1
23	31740	Bolt, hex - 1/2-13 x 2"	4
24	31460	Spacer - 1/2 id x 5/8	4
25	31078	Washer, lock - 1/2"	4
26	31022	Nut, hex - 1/2-13	4
27	27400	Cover, Drive belt top	1
28	31660	Bolt, 'F' thread - 5/16 x 3/4	4
29	27399	Cover, Drive belt side	1
30	31660	Bolt, 'F' thread - 5/16 x 3/4	4

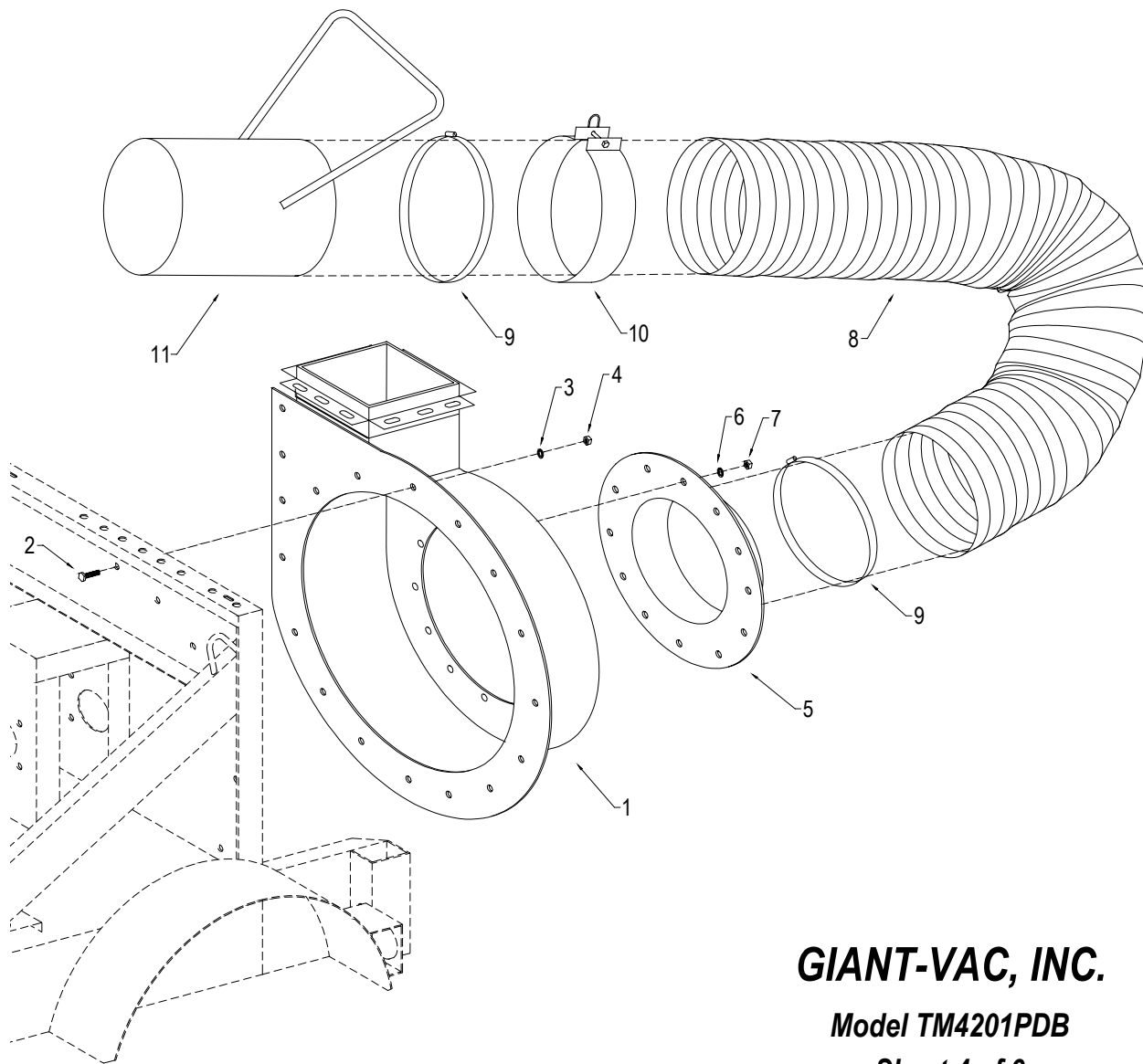

GIANT-VAC, INC.

Model TM4201PDB

Sheet 4 of 6

Intake Group

R0603.1

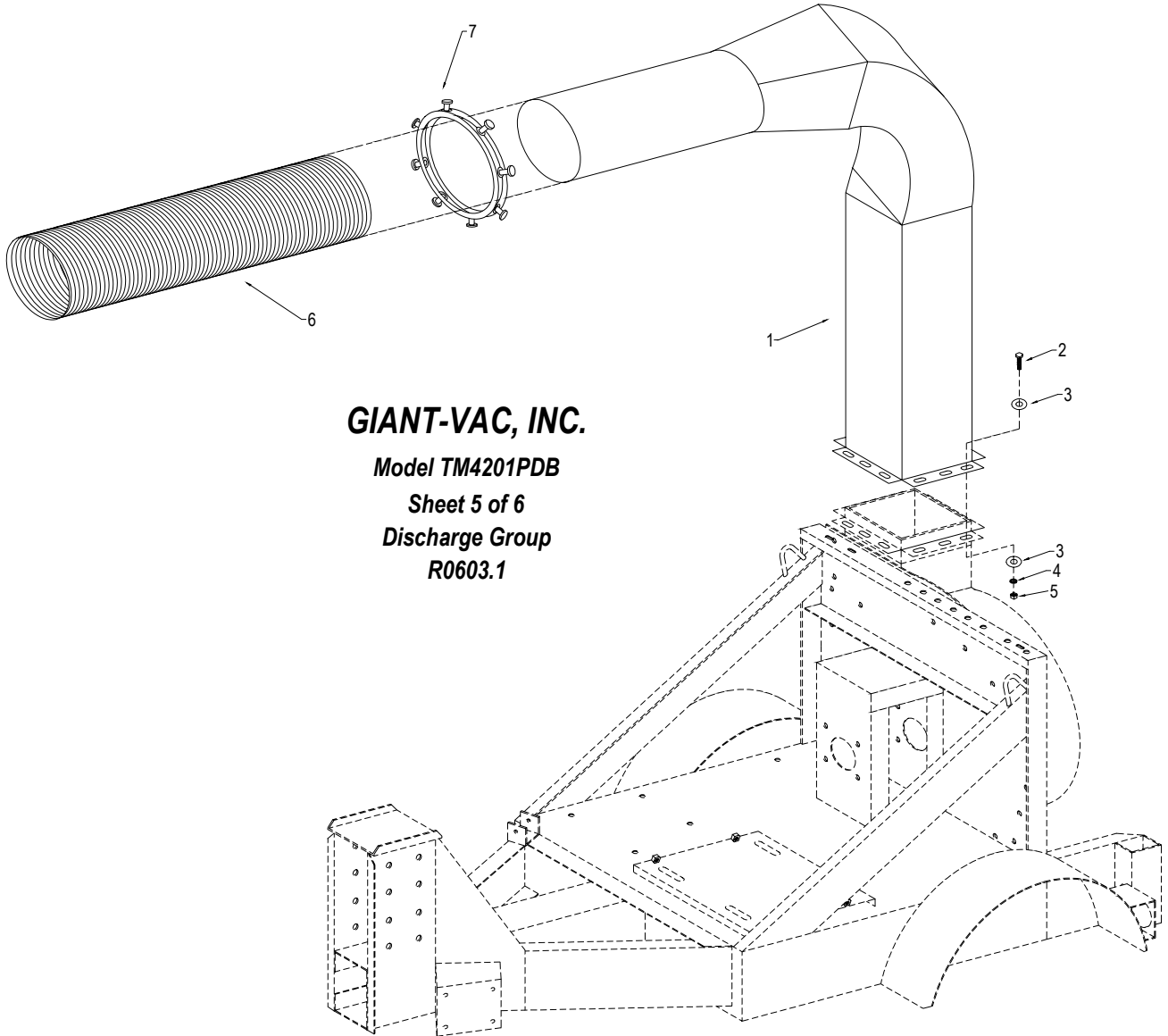

GIANT-VAC, INC.

Model TM4201PDB

Sheet 5 of 6

Discharge Group

R0603.1

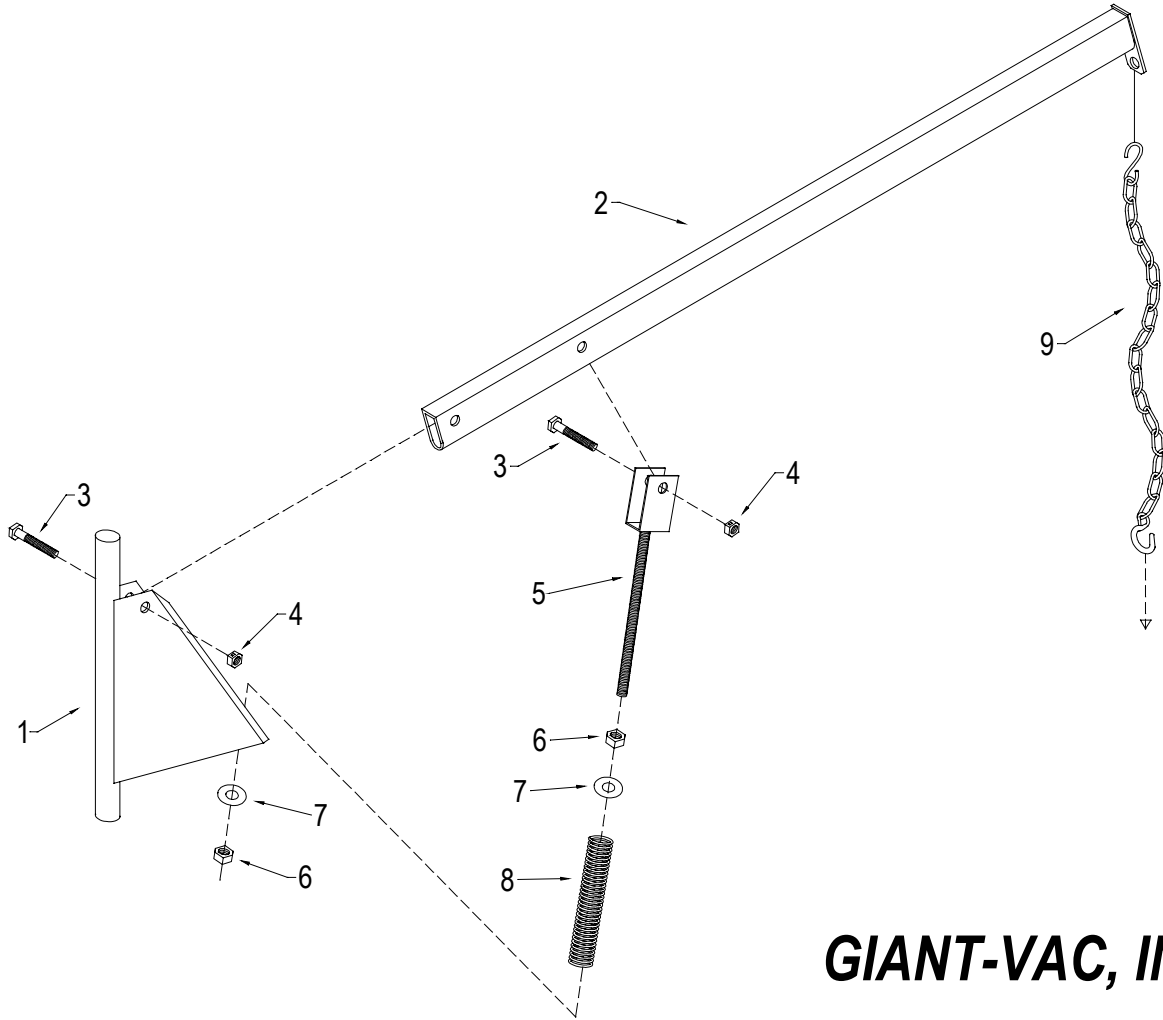

GIANT-VAC, INC.
Model TM4201PDB
Sheet 6 of 6
Hose Support Boom Group
R0603.1

Giant-Vac Model TM4901JDB Truck Loader

R0603.1

REF #	PART #	DESCRIPTION	QTY
SHEET 4 - INTAKE GROUP			
1	10220	Housing, impeller – complete with liner kit below	1
---	70788	Liner, 2-pc replaceable wear – with hardware (specify Model 4201)	1
2	31033	Bolt, hex - 3/8-16 x 1"	13
3	31008	Washer, lock - 3/8"	13
4	31009	Nut, hex - 3/8-16	13
5	34058	Flange, intake, 16" 90 degree	1
6	31078	Washer, lock - 1/2	12
7	31022	Nut, hex - 1/2-13	12
8	34022	Hose, intake - 16" x 7'	1
9	34024	Clamp, hose - 16"	4
10	40111	Band, hose support – 16" – with hardware *	1
--- *	31141	Bolt, hex – 5/16-18 x 3-1/2" (support band hardware)	1
--- *	31004	Nut, hex - 5/16-18	2
11	20157	Nozzle, intake - 16"	1

SHEET 5 - DISCHARGE GROUP

1	24628	Stack and elbow assy	1
2	31512	Bolt, hex - 1/2-13 x 1-3/4"	12
3	31043	Washer, flat - 1/2	24
4	31078	Washer, lock - 1/2"	12
5	31022	Nut, hex - 1/2-13	12
6	34026	Hose, discharge - 12" x 6' metal	1
7	34049	Ring, squeeze - 12"	1

SHEET 6 - HOSE SUPPORT BOOM GROUP

1	40159	Boom vertical member new bearing style	1
2	40106	Boom horizontal member	1
3	31333	Bolt, hex – 1/2-13 x 3"	2
4	31406	Nut, reverse lock – 1/2-13	2
5	40108	Guide, threaded spring	1
6	31110	Nut, hex – 3/4-10	3
7	31370	Washer, flat – 3/4"	2
8	31332	Spring, boom	1
9	31140	Chain, boom – 48" w/2 S-hooks	1
10	36299	Bearing, Flanged 1.50	2

ALL SPECIFICATIONS SUBJECT TO CHANGE WITHOUT NOTICE

WARRANTY

Janiak Manufacturing, Inc., here-in-after called Giant-Vac™ Municipal , will warrant each new Giant-Vac product to be free from manufacturing defects in normal service for a period of one (1) year for municipal use. This warranty extends only to the original purchaser of the product and cannot be transferred. This warranty does not apply to engines, tires or other items that are purchased by Giant-Vac and warranted by the manufacturer of such items. Items such as; bags, grass catchers, hoses and blades are not warranted, as these are considered expendable items. This warranty does not include equipment failures due to normal wear.

Any obligation under this warranty is expressly limited to the replacement or repair, at an authorized servicing Giant-Vac™ Municipal dealer, or at a point designated by us, of such parts as appears to us to have been defective. All defective parts have to be returned freight prepaid before credit will be issued.

We shall not be liable for transportation charges in connection with the replacement or repair of defective parts.

This warranty does not apply to a Giant-Vac™ upon which repairs or alterations have been made by others except with our prior written approval.

We shall not be liable for consequential damages or contingent liabilities for the fitness of any Giant-Vac™ for any particular purpose.

We make no other express, implied or statutory warranty, nor is anyone authorized to make any in our behalf.

Engines are a separate warranty (Claims for parts, labor and mileage are to be filed directly with Engine Manufacturer/Local Dealer not Janiak Manufacturing):

Wisconsin – One (1) year warranty direct from Wisconsin

John Deere – Two (2) year warranty direct from John Deere

Janiak Manufacturing, Inc.

P.O. BOX 195
SOUTH WINDHAM, CT. 06266
PHONE: 860-423-7741 • FAX: 860-423-2654

WARRANTY REGISTRATION

SOLD TO: _____

DEALER: _____

Giant-Vac MODEL: _____

SERIAL #: _____

ENGINE MODEL: _____

SERIAL #: _____

PURCHASE DATE: _____

ORDER#: _____

MANUFACTURER: **Janiak Manufacturing, Inc.**
P.O. BOX 195
South Windham, CT 06266

DESCRIPTION:

Janiak Manufacturing Warranty

JANIAK MANUFACTURING, INC., here-in-after called Giant-Vac™ Municipal, warrants each new Giant-Vac™ Municipal machine to be the original retail purchaser of new Giant-Vac™ Municipal equipment to be free from manufacturing defects in normal service for a period of one (1) year unless it is used for rental purposes which limits the warranty to 30 days. This warranty does not apply to engines, tires or other parts that are manufactured and warranted by the manufacturer. Items such as bags, grass catchers, hoses and blades are not warranted as these are considered expendable items. This warranty does not include equipment failures due to normal wear.

An obligation under this warranty is expressly limited to the replacement or repair at an authorized servicing Giant-Vac™ Municipal dealer, or at a point designated by us, of such part or parts as shall appear to us to have been defective. All defective parts have to be returned freight prepaid before credit is issued.

We shall not be liable for transportation charges in connection with the replacement or repair of defective parts.

This warranty does not apply to a Giant-Vac™ Municipal machine upon which repairs or alterations have been made by others except with our prior written approval.

We shall not be liable for consequential damages or contingent liabilities nor for the fitness of any Giant-Vac™ Municipal machine for any particular purpose.

We make no other express, implied or statutory warranty, nor is anyone authorized to make any in our behalf.

Engines are a separate warranty: (claims to be filed directly with Engine Manufacturer/Distributor)

John Deere – Two (2) year warranty direct from John Deere

Wisconsin – One (1) year warranty direct from Wisconsin